

Evacuation System Monitoring

FX100 USE CASE



The responsible security authorities of a nuclear power plant requested to retrofit the existing PA evacuation network with an automated monitoring system.

The solution was established with FX100 Audio analyzer + RT-IB 100V speaker impedance box, which were successfully integrated in the existing infrastructure without structural changes.

The implemented system verifies not only the proper operation of the connected PA loudspeaker lines, but also the electrical alarm signal generator and the microphone in the control room.

Flexus FX100 



The challenge

Driven by tighter security regulations, the operators of a nuclear power plant requested the implementation of an automated acoustic & electrical test for the existing PA evacuation system.

The specification included the periodic verification of the installed loudspeakers, the alarm signal generator and the microphone in the control room that is used for verbal announcements.

The monitoring device therefore had to execute both electrical and acoustic measurements. The scheduling and triggering of the individual test procedures is handled by an external PLC.

The Solution

The FX100 Audio analyzer is the heart of the monitoring network. Its generator is linked to the loudspeakers through a switcher matrix, while the analyzer is connected to the speaker lines, the alarm signal generator, and the microphone in the control room.

The verification cycles are initiated by the PLC through a PC that activates the switcher states and triggers the FX100 measurements accordingly.

NTi Audio therefore also provided a custom-tailored software extension for RT-Speaker that communicates with the host controller via TCP/IP interface.



Highlights:

- Fully automated monitoring of hundreds of loudspeakers, the alarm signal generator and the control room microphone.
- Installation of the monitoring system was accomplished without the need for structural changes.

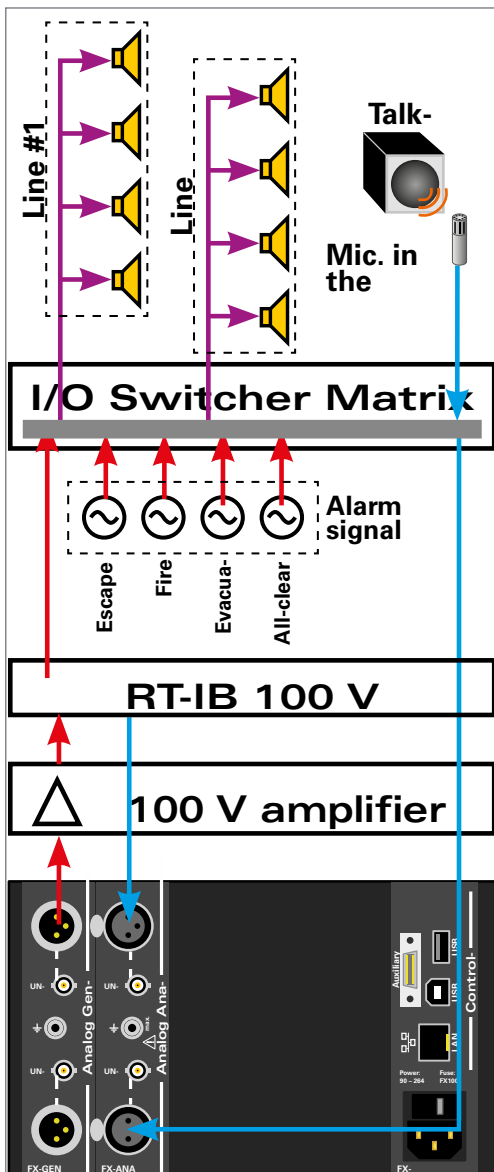

System overview

Hardware

- NTi Audio FX100 2-chn Audio analyzer
- 100 V Audio amplifier
- NTi Audio RT-IB 100 V impedance test box
- Audio switcher matrix (e.g. NTi Audio OS-0210 and IS-1002)
- NTi Audio TalkBox TB1

Control software

- RT-Speaker

Measurements

- Impedance response of 100 V loudspeakers
- Frequency-level patterns of the alarm signals
 - Level of the microphone signal