

Audio Measurement System For Analog & Digital Analysis

- Portable
- User Friendly
- Large LC Display
- PC- and Printer Communication
- Storage Capabilities for 4 Graphs
- Highest Performance and Reliability



History

Over the past 25 years NTi Audio (previously part of NEUTRIK-group) has been on the leading edge of audio technology by manufacturing innovative, superior quality connectors and high performance, cost-effective audio measurement equipment. Our combined user base comprises over 10,000 units of audio test sets around the world and a satisfied customer base including military, telecom, aerospace, professional audio, broadcasters, educational industry, industrial manufacturers and research and development firms.

In March 2000 the audio measurement division of Neutrik has been separated in cause of a management buy out forming the new company NTi Audio. NTi Audio and Neutrik are fully independent companies.

Our team of engineers is committed to research in the latest technology in order to meet the challenges of the future. Our sales and after sales services are supported in many countries around the world with highly qualified, technically trained personnel.

Our mission to be leaders in our industry derives from our pursuit of perfection and customer satisfaction.

System Overview, Features

The A2 and the A2-D are state-of-the-art fully automatic, high performance audio measurement systems. Equipped with both a generator and a comprehensive measurement section, the instruments can completely characterize virtually all audio performance parameters including level, gain, frequency response, total harmonic distortion, intermodulation distortion, noise, wow & flutter, drift, crosstalk, phase and spectrum analysis.

Rapid measurement settling allows use of the instrument in production or R&D. The instrument can be controlled via a user-friendly front panel interface, making even complicated measurement tasks very simple. A RS232 remote control interface as well as an IEEE 488 interface allow full remote operation of all functions.

Following the latest trends in audio technology the A2-D is capable of handling analog and digital signals. This ensures that a single, selfcontained instrument can do all the required tests in mixed signal environments with simplicity, and offers superior graphical and documentation capabilities.

The use of advanced technologies such as digital signal processors

ensures a large growth potential towards meeting the challenges of future technologies.

The A2 is very price competitive since it combines many features, usually found only on separate analog and digital analyzers, in one unit, costing less than competitor's equipment.

- Easy-to-read, large high resolution graphics display. Single measurement values are shown as giant characters and with a bargraph, response curves in a properly scaled graph with up to six traces and time dependent signals in the auto-scaling scope screen.
- Amplitude-, time-, frequency- and tablesweep capability over the entire range of the internal generator or with external synchronization.
- Intelligent auto-scaling, -ranging, -tuning and -nulling for maximum operational convenience.
- Storage/Recall of four complete graphs with up to 6 traces each in the non-volatile memory for later printout or transfer to a PC.
- Easy, precise and quick generator setting with bandless knobs.
- Dedicated controls for each function.
- Intelligent window technique for configuration settings.

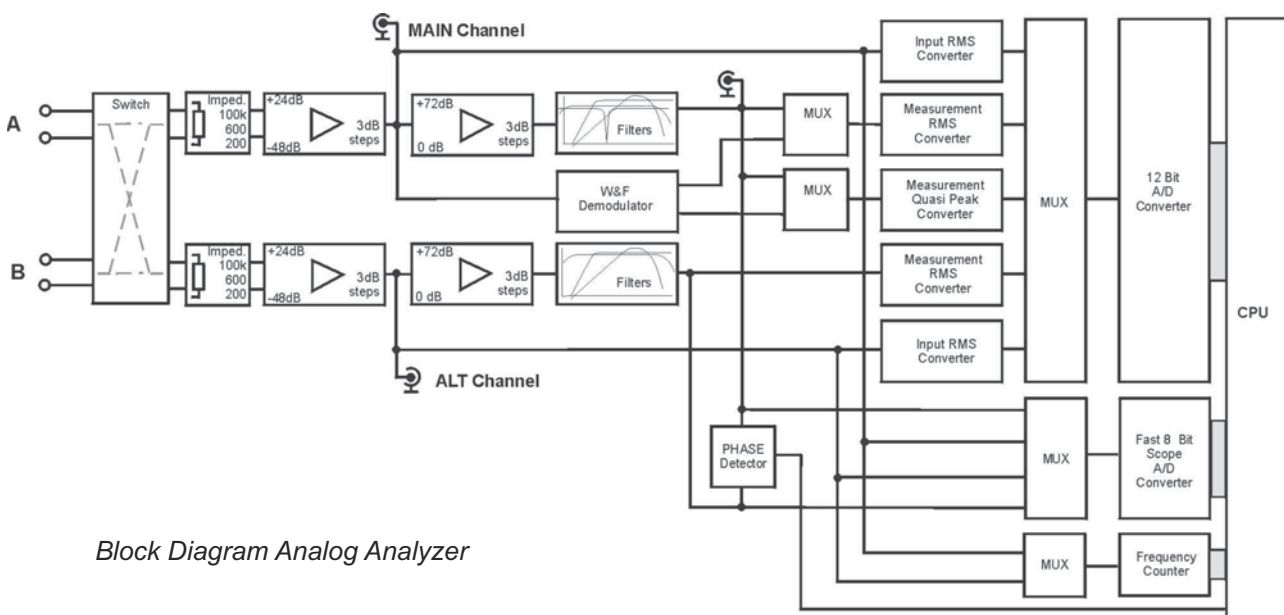

Block Diagram Analog Analyzer

- Auto detection of analog / digital signal inputs (A2-D).
- Functional, EMI proof, all metal, easily stackable and rack-mountable cabinet.
- DSP generator for cleanest signals with literally no limitations in signal shape: sinewave, symmetric and asymmetric square wave, white/pink noise, warble- and dualtone signals included.
- Extended capabilities with PC control: Windows™ based driver software package AS04 via RS232 or IEEE-488 interface.

Generator

The high performance DSP based generator covers a frequency range from 10Hz to 100kHz with residual mid-band distortion below 0.0015%. Level ranges from 10µV up to +24.5Vrms. Alternate signals provided with the DSP flexibility are

- Square
- Triangle
- White Noise
- Pink Noise
- Warbled Sine
- IMD Signals

The electronically balanced, floating output stage can be complemented with an optional output transformer.

The generator can be swept not only over frequency but also over the entire amplitude range with freely selectable start/stop values.

The table feature allows to define discrete measurement points in a sweep table.

Digital Generator Features

The digital generator samples at the three standardized frequencies of 32kHz, 44.1kHz or 48kHz or can be locked to either the analyzer input clock or to an external house clock. It provides full access to status and user bits. Resolution of the generated signal can vary from 4 to 24 bits. Supported waveforms are: Sine, Dithered Sine, Pass-Mode and Dithered Pass-Mode.

The sampling frequency can be detuned in the range of ±1500ppm to check the locking range of the DUT's PLL circuitry.

The implemented Jitter generator allows adding defined Jitter values from 2ns up to 40ns. The modulation signal can be selected between a sinewave or white noise; there is literally no signal limitation.

Furthermore, the carrier level can be reduced and indicated from the nominal 5V (AES/EBU spec) to levels as low as 0.15V. The variation of these parameters allows one to easily draw a picture of the acceptance range of the device under test and gives a quick impression of the available safety margins in an installation.

Dithering of the generated signals with the TPDF can be activated also in the Pass mode, where the output provides a clock synchronous signal as presented at the analyzer's input but with possible alteration of status information, transmission format e.t.c. This way the A2-D can be used as a problem solver at an interface, filtering or inserting certain bits.

Analyzer

The two independently and simultaneously operating inputs are balanced and fully differential with selectable input impedances of 200ohm (150ohm), 600ohm and 100kohm. Phantom power of +15V or +48V is available as an option. The inputs can handle levels from as low as 1.2µV up to 200Vrms.

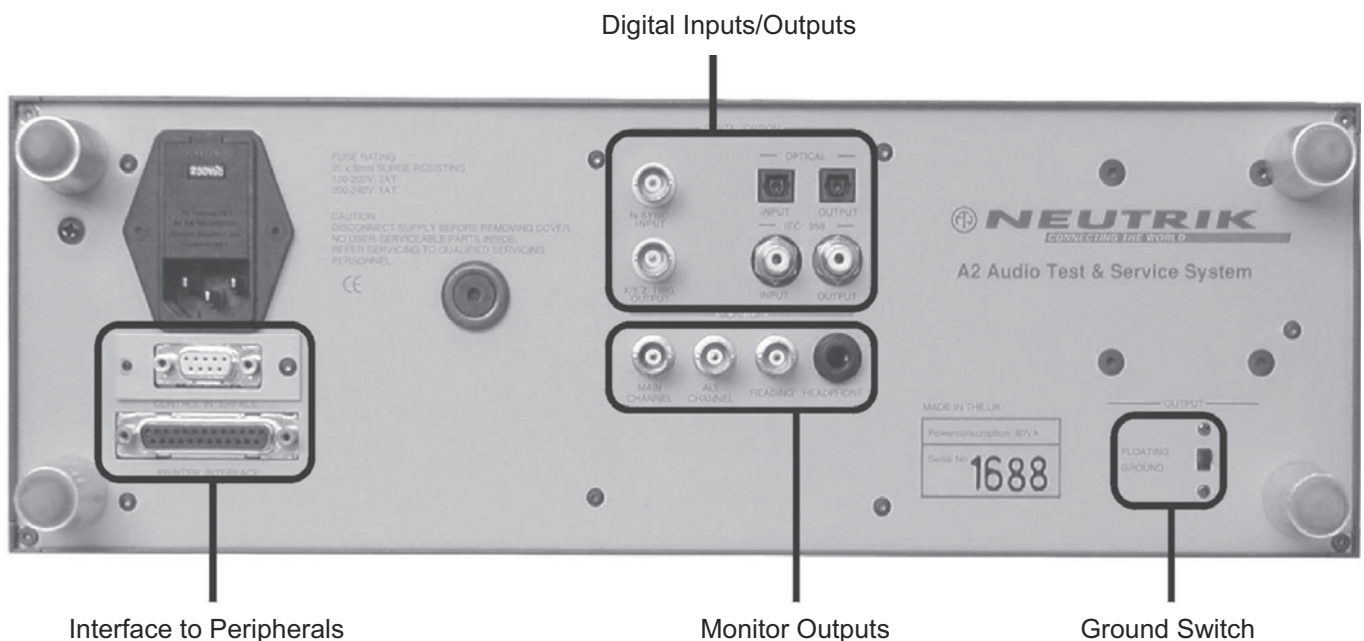

Rear Panel A2-D with RS232 interface

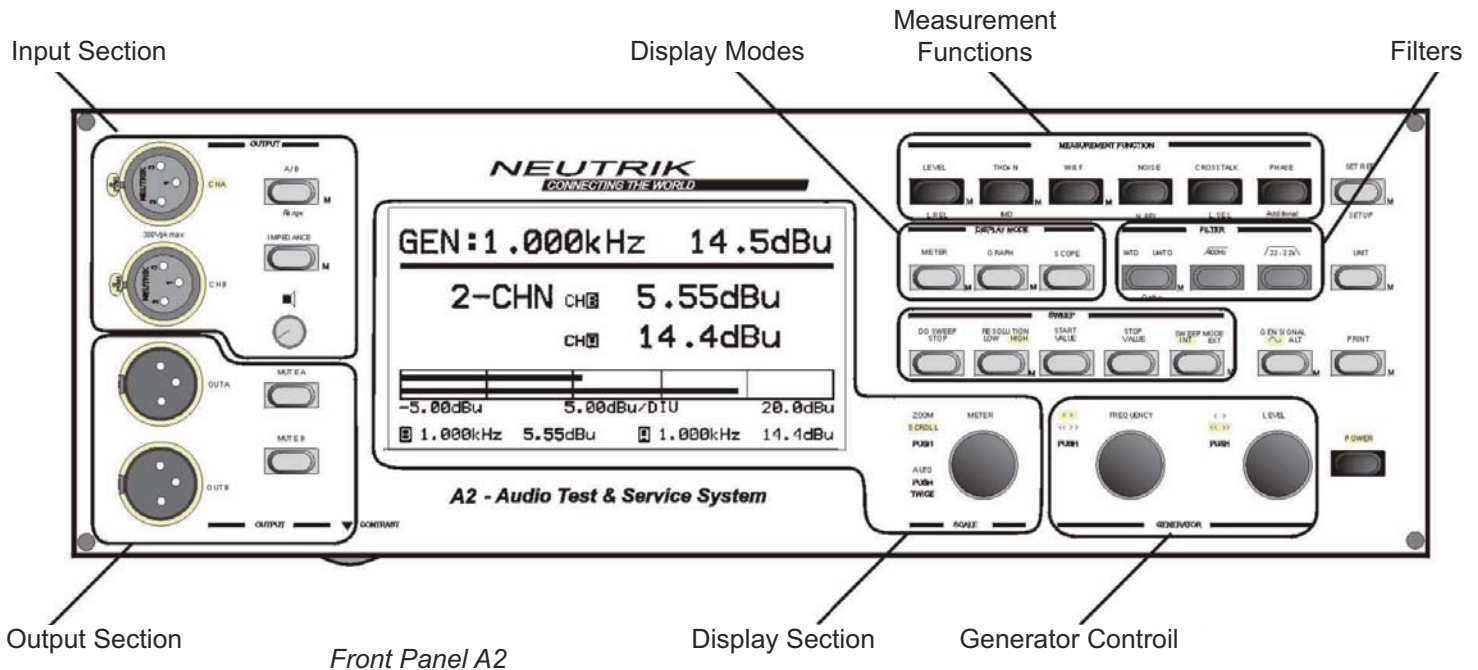

The input levels are continuously measured and displayed for both channels. A very fast peak ranging circuitry adjusts gain automatically for lowest noise and distortion.

A 400Hz high pass, 22Hz - 22kHz band pass, CCIR 468 noise weighting filter as well as the W&F weighting filters are included as standards. Sockets are provided for four additional weighting filters (two per channel).

Analog Functions

In order to speed up tests, the comprehensive analog analyzer section of the A2 and the A2-D provide simultaneous two channel measurements for

- Level
- Crosstalk
- Frequency
- Level-ratio
- Phase
- Scope

and fully automatic

- Total Harmonic Dist. (THD+N)
- Noise
- Wow & Flutter
- Drift
- Intermodulation Distortion
- Narrow Band Selective Level
- Spectral FFT Analysis

All functions are available in linear or logarithmic units in absolute and relative terms.

The two channel digital storage oscilloscope is self triggering, auto-scaling and -ranging, equipped with a time-base optimizing algorithm. Thus no adjustments are required to obtain a display of the signal waveform. A "Store" function allows freezing the scope screen.

Monitoring

The built-in speaker and headphone jack with adjustable volume allow monitoring the analog and digital audio signals. Three additional BNC-type outputs are provided; one each for the auto-ranged input signals and one for the reading output, representing the processed signal right before the rectifiers (e.g. residuals in THD).

Digital Functions (A2-D)

An innovative digital interface option supports measurements in a digital signal environment, where connectivity problems like emphasis, sampling rates, consumer/professional formats occur regularly.

The interface acts as a problem solver allowing the analysis of the bitstream in the two standard formats, - AES/EBU and IEC958 (SPDIF). AES/EBU can - for easiest operation - be directly fed into the front XLR connectors. No matter what the signal type is, the smart input stage automatically detects the signal type and switches into the appropriate analysis mode.

In addition RCA and optical TOS link connectors for input and output of SPDIF signals are provided at the back of the instrument.

Regardless of the selected source, the available analysis functions are

- Carrier Level
- Jitter Analysis
- Bit Statistics
- Sampling Freq.
- Peak Level
- Status Analysis

With the internal high performance D/A converter it is furthermore possible to perform analog analysis of the digital signal

- Total Harmonic Dist. (THD+N)
- RMS Level
- Monitoring (speaker & headphone)

The continuously displayed carrier level, sampling frequency and jitter provide an accurate image of the condition of the incoming signal.

A2-D analyses the word-clock jitter in the range of 1ns up to the 40ns where most professional equipment fails to track.

The measured sampling frequency can be displayed in absolute terms or as a deviation from the next standardised sampling rate in ppm.

The main content of the status information is also continuously decoded, while the analysis mode "Status" provides a complete and clearly readable analysis of the bits - for the professional as well as for the consumer format.

The Bitstatistics screen illustrates the activity of all bits in a subframe, thus easily allowing one to find the real audio data resolution or possibly hanging bits.

The peak-level measurement continuously displays - as with analog signals - both channels simultaneously with large characters and the dual trace bargraph.

Available units are dBF, %, and LSB. LSB units are very helpful to indicate how many bits are occupied or left unused before reaching full scale.

A powerful FFT analysis (optional in some markets) allows one to perform Fast Fourier Transformation with the incoming analog signal. It provides a high resolution spectral display up to 5kHz or 20kHz for full audio bandwidth with a block length of 2048 samples. Different windows like Hanning or Flat-Top, can be selected for optimized results.

Furthermore, a D/A converted signal can be fed into the analog analyzer path to do conventional audio analysis with the digital bitstream.

The analyzer locks to sampling rates of 32kHz, 44.1kHz and 48kHz - but accepts any sampling rate in the range from 25kHz to 52kHz - or can be locked to an external house-clock signal.

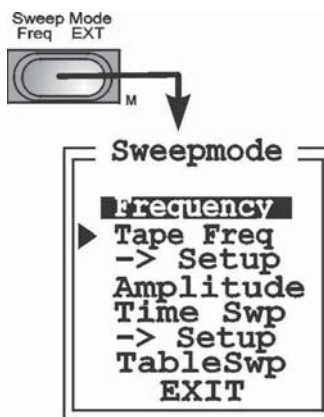

Sweep Menu

Sweeps

Frequency response sweeps, the most frequent used application to prove the quality of an audio device, are automatically performed by a single keystroke. The amplitude sweep facility of the A2 - without an external PC displays within seconds the MOL of a tape or the characteristics of a compressor limiter.

The time sweep, specialized to monitor results of a measurement function, to find intermittent faults or to get a data base for average levels, can be set to values from seconds up to days.

The table sweep facility allows to load a userdefined sweep table into the memory of the A2. The table may contain pairs of frequency and level to maintain e.g. constant modulation or de-emphasis of any frequency characteristic.

A mixed signal mode, generating digital and analyzing analog or vice versa, simplifies test of A/D and D/A converters.

Storage Capabilities

Several traces of the same sweep type may be overlayed and rescaled together in a graph. A maximum of six traces can be kept, rescaled, stored and printed in one graph.

Four complete, independent graphs can be stored in the internal non-volatile memory. Each stored graph is complemented with a time/date stamp of the clock. This simplifies field measurements, where carrying a printer is too awkward.

Display

Measurement results are shown on a latest generation 256 x 128 backlit graphics LC-display with large and easily read characters, completed by two bargraphs representing the amplitudes of both input channels.

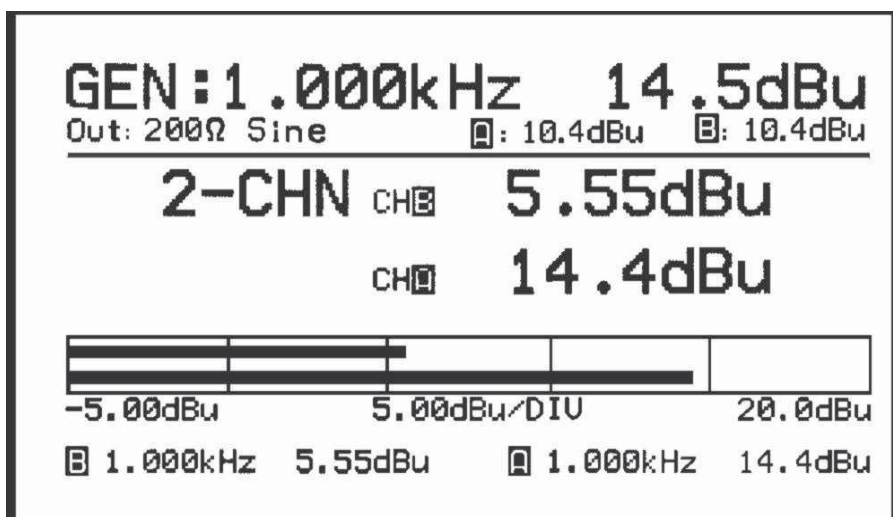

METER Display

AS04 - Windows™ Based Remote Control Software for A2-D

Basic Concept

The AS04 software package not only provides full access to all analog and digital functions of A2/A2-D instruments, but also enlarges its capabilities by far with an extended row of additional features. Communication between a PC and the test instrument may be established either through a high-speed RS232 serial interface or a IEEE-488.2 parallel interface.

Basically, AS04 supports all available standard functions of an A2 instrument, including the features of additionally installed options as e.g. digital mode or FFT spectrum analysis. Furthermore, a sophisticated sweep curve calculation panel or a programming tool for automated processes enable the operator to carry out virtually all possible measurement tasks.

Panel Structure

All related functions such as generator or analyzer settings are comprised in separate, clear

panels, displaying the actual status as well as offering access to all available settings. For the display of measurement results, a Meter panel and up to eight Bargraphs may be opened in parallel. Sweep- and FFT-setup as well as their graphics are displayed in separate panels, which may be printed out at any time. Frequently used set-ups, together with all recorded curves and optional tolerance bands may be saved and loaded if required.

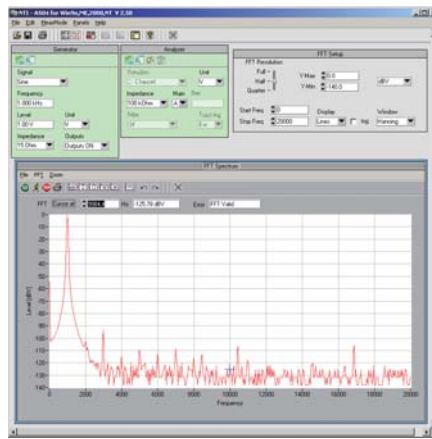

AS04, FFT Display

Automated Applications

An easy-to-learn programming tool called AMSL (Audio Measurement System Language), being very similar to BASIC, allows to write complete sequences for automated tests. Its thought-out command set for program flow control, measurements, input / output, calculations and advanced system handling tasks satisfies almost all requirements without limitations.

Automated sequences may be structured in small units and called up individually by a main program, thus saving a lot of routine work.

Requirements

- IBM 386 compatible computer or higher with coprocessor and at least 8MB RAM as well as 5MB harddisk memory
- Windows™ 3.11, 95, 98, 2000, XP operating system installed
- 1x CD drive and a RS232 or GPIB interface port for communication
- Mouse operation is recommended but not compulsory

Available Options

- AO4** A-weighting filter
- AO5** User filter (custom design of frequency response)
- AO7** Transformer output
- AO8** Phantom power option for +15V or +48V
- AO10** Digital option
- AO11** IEEE-488 Interface.
- AO12** FFT option for A2-D
- AO13** C-message filter
- AO14** 80kHz lowpass filter
- AO16** High-speed RS 232 interface including AS04
- AO17** IEEE interface including AS04
- AA10** Softbag with poche for cables and accessories (in-bag operation of A2)
- AA21** Service & calibration manual for A2

Application Notes

- AES/EBU Measurements with A2-D**
Background Information about AES/EBU definition and its measurements.
- Measurements in Studio Environment**
Practical measurements with A2 in studios. Set-ups, alignment, automation.
- Tape Recorder Service**
Adjustments and measurements with A2 on tape recorders. Set-ups, documentation.
- Sound Pressure Level Calculation**
- Unbalanced Connections**

Specifications A2 & A2-D

Analog Generator

Signals: Pure & Warbled Sine, Symmetric- & Asymmetric Square Wave, Triangular Wave, Pink & White Noise, IMD Test signals (see IMD).

Frequency range	10Hz to 100kHz (sine)
Frequency resolution	< 0.05%
Frequency accuracy	± 0.01% of defined value
Output level	10 μ V to 24.5Vrms (-100dBV to 27.6dBV)
Level resolution	< 0.05dB
Level accuracy (o.c.)	0.5% of defined value.
Flatness	± 0.05dB, 20Hz to 20kHz, Ref = 1kHz, 0.05% typ.
Output impedance	< 15 Ω , 150 Ω (200 Ω), 600 Ω
Residual THD+N	typ. <-89dB (0.002%) <-92dB max. or 10 μ V 20Hz to 20kHz, unloaded DIN Audio BP
Square wave	Rise & fall time <5 μ s (unloaded)
IMD signal	f1: 60Hz or 250Hz, f2: 4kHz to 40kHz, ratio 1:1, 4:1, 10:1, sweepable

Digital Generator

Output format	Professional acc. to AES-3 and Consumer acc. to IEC958 optical TOS Link
Impedance	110 Ω , 75 Ω
Sampling frequency	32kHz, 44.1kHz, 48kHz or input clock or analyzer clock
Accuracy	±10 ppm, ±2 ppm on requ.
Detune	±1500ppm
Resolution	4 bits to 24 bits.
Dithering	TPDF switchable
Jitter generation	2ns to 40ns with selectable modulation signal
Output level	0.15Vpp, 5Vpp
Trigger Output	X-, Y-, Z-Preamble, Bitclock

Sweep Function

Mode	Frequency-, Amplitude-, Time- and Tablesweeps over entire generator range.
Sweep resolution	3 to 200 points.
External sweeps	Automatically synchronised.

Analog Analyzer

Number of channels	2 simultaneously operating, balanced, fully differential.
Impedance	100k Ω /50pF, 600 Ω , 200 Ω (150 Ω) selectable.
Input voltage	Max. 300V peak / 200Vrms.
Phantom power	Optional +15V or +48V replaces 150 Ω , (200 Ω), impedance.
CMRR	>80dB, (20Hz to 20kHz)

Digital Analyzer

Input format	Professional acc. to AES-3 and CONSUMER acc. to IEC958, Optical TOS Link
Impedance	110 Ω , 75 Ω
Sampling frequency	32kHz, 44.1kHz, 48kHz, house clock or input clock
Locking range	25kHz to 52kHz
Meas. accuracy	2 ppm
Jitter function	0,1ns to 40ns continuously measured
Input level	0.1Vpp to 10Vpp

LEVEL

Range	1 μ V to 200V (-120dBV to +46dBV)
Residual Noise	<1.5 μ V (Short circuit, 22Hz to 22kHz)
Flatness	±0.05dB (20Hz to 40kHz) ±0.1dB (full band)
Rectifier type	RMS
3dB bandwidth	>250kHz

HARMONIC DISTORTION (THD+N)

Fundamental range	10Hz to 50kHz
Display range	0.001% to 100% (-100dB to 0dB)
Input voltage	5mV to 200V
Residual THD+N	<-95dB typ. (DIN Audio BP)
Input >0dBV	<-90dB (0.0025%)
3dB bandwidth	2Hz to 250kHz
Rectifier type	RMS

PHASE

Frequency	10Hz to 100kHz
Level range	10mV to 200V
Level difference	<18dB
Accuracy	± 1° (20Hz to 40kHz)

IMD

Standards	DIN 45403, SMPTE and TH 22.51
Frequency ratio	1:1, 4:1, 10:1
Low frequency	60Hz or 250Hz
High frequency	4kHz to 40kHz sweepable
Residual IMD	<-86dB typ.

CROSSTALK / SELECTIVE LEVEL

Range	10Hz to 50kHz
Accuracy	± 0.3dB
Filter	Tracking 2-pole BP, Q = 5
Rectifier	RMS
Residual noise	<0.7 μ V (< -123dBV) (Ref=1kHz, DIN Audio BP)

NOISE

Filter weighted	CCIR 468-4
Filter unweighted	DIN Audio Bandpass, 22Hz to 22.4kHz
Rectifier	Quasi-Peak According to CCIR 468-3
Residual noise	<-104dB WTD (QP) <-108dB UWTD (QP) <-116dB WTD (RMS)

WOW & FLUTTER

Standards	IEC 386, DIN 45507, CCIR 409, BS4047(QP) NAB, JIB C 5551 (RMS)
Range	>10% to 0.1% full scale
Accuracy	± 3% of reading
Frequency	3kHz or 3.15kHz
Input voltage	100mV to 100V

DRIFT

Range	± 15%
Accuracy	± 20ppm (± 0.002%)

FREQUENCY

Display mode	Continuous
Frequency range	10Hz to 200kHz
Resolution	min. 0.1%
Accuracy	± 0.05%

SCOPE FUNCTION

Trigger mode	Auto
Scaling	Auto, 100 μ V to 20V / Div
Time base	Auto, 10 μ s to 20ms/Div
Sampling rate	Max 2 Million / second

FILTERS

400Hz highpass	± 10%, 3-pole
Bandpass	22.4Hz to 22.4kHz (DIN), ± 10%, 3-pole
Noise filter	CCIR 468 / 4
Selective filter	2-pole tracking bandpass, Q=5
Psophometric filter	A-weighting filter acc. to IEC651, (optional)

Display

256x128 dot backlight graphics LCD module.
Measurement display with large 15mm numeric
values and two 100mm bargraphs.

Interfaces

Centronics compatible, parallel printer port (25pin
sub D) for graphics and text printouts. Supports
Epson FX and LWQ, IBM Proprinter, HP Deskjet,
Thinkjet and Laserjet printers (PCL 3 or PCL 5
compatible)

RS232 serial port (optional) for remote control and
data transfer between A2 and IBM PC compatible
computer.

IEEE-488 parallel remote control interface (optional)
for remote control and data transfer between A2
and PC. LabView® supported.

BNC monitor outputs offering both input channels
and reading signal, Level: typ. 3Vpp, Rout = 600 Ω

General Data

Dimensions	274 x 396 x 132mm (11" x 15" x 5")
Weight approx.	9kg (20 lbs)
Power requirements	100V, 120V, 230V, 240V 85VA
Temperature range	0 to 45°C (32°F to 113°F).
Humidity	10% to 90% RH non cond.