



User's Guide

Audio Input Switcher IS1002



Document V 1.03 / 0e
Related to Firmware V1.03



*NTI is an ISO 9001
certified company*



Table of contents

- Scope..... 3**
- Declaration of Conformity 3**
 - CE / FCC compliance statement..... 3
 - Disposal and recycling 3
- Warranty conditions 3**
 - International warranty 3
 - Limitations 3
 - Repairs 3
- 1 Introduction 4**
 - 1.1 Overview 4
 - 1.2 Applications..... 4
 - 1.2.1 Speaker testing with several mics..... 4
 - 1.2.2 Stereo device testing 4
 - 1.2.3 One analyzer for several test jigs..... 4
- 2 System setup 5**
 - 2.1 Control interface 5
 - 2.2 Address assignment..... 5
- 3 Functional description 6**
 - 3.1 Power supply 6
 - 3.2 5-in-2 vs. 10-in1 operation 6
 - 3.3 LEDs 6
 - 3.4 Microphone power 6
 - 3.5 Ground lift..... 6
 - 3.6 Cascading via daisy chain..... 6
 - 3.7 Rack mounting 6
- 4 Operation..... 7**
 - 4.1 Control elements 7**
 - 4.2 Control software..... 8
 - 4.2.1 Installation 8
 - 4.2.2 Operation..... 8
- 5 Technical specifications 9**
 - 5.1 Electrical 9
 - 5.2 Mechanical 9



Scope

This document describes the installation and general operation of the IS1002 input switcher. Programming related information can be found in the "IS1002 Developer's Guide".

NOTE The PC-software tunkey solutions from NTI (e.g. RT-Speaker) already comprise the automated control of connected input switcher(s).

Declaration of Conformity

CE / FCC compliance statement

We, the manufacturer
NTI AG
Im alten Riet 102
9494 Schaan
Liechtenstein, Europe

hereby declare that the input switcher IS1002, approved in 2007, complies with the following standards or other standard documents.

EMC	89/336, 92/31, 93/68
Safety	EN 61010-1
Harmonized standards	EN 61326-1

This declaration will become invalid if modifications to the instrument are carried out without the written approval of NTI.

Date 01.11.2007

Signature *M. Becker*

Position Technical Director



Samples of this instrument have been tested and found to conform to the statutory protective requirements to be given the CE mark.

Disposal and recycling



Dispose of your instrument in accordance with the legal environmental regulations in your country.

Warranty conditions

International warranty

NTI guarantees the function of the IS1002 for a period of one year from the date of sale. During this period, defective instruments will be repaired free of charge, or will be replaced.

Limitations

These guarantee provisions do not cover damage caused by accidents, transportation, incorrect use, carelessness, accessories or the installation of any parts that were not delivered with the instrument, the loss of parts, connection to the mains voltage, operation with non-specified input voltages or adapter types. In particular, NTI accepts no responsibility for subsequent damage of any kind. The warranty will be voided by the carrying out of repairs or service work by third parties who are not part of an approved NTI Service Centre.

Repairs

In the case of faulty functioning or damage, send the instrument to the local NTI agency in your country in its original packaging. Please enclose a precise description of the fault. You can find the contact addresses on the NTI Internet page www.nti-audio.com

Repair work will only be carried out under warranty upon presenting the original sales receipt.

1 Introduction

1.1 Overview

IS1002 is an advanced, multi-functional audio input switcher that offers the following key features.

- 10 input and 2 output channels for 2*5:2 or 10:1 operation,
- Individual Phantom (2 V or 48 V) or ICP® microphone power supply for all input channels,
- Individual channel status indication via two-color LEDs,
- Ground lift,
- Remote controlled via USB,
- Cascading of up to 8 via RS485 daisy chain supported,
- .NET assembly.

1.2 Applications

The following chapters provide a rough overview on typical applications for the IS1002 input switcher.

1.2.1 Speaker testing with several mics

This setup is typically used for woofer testing, where the acoustical DUT characteristics must be verified from different positions.

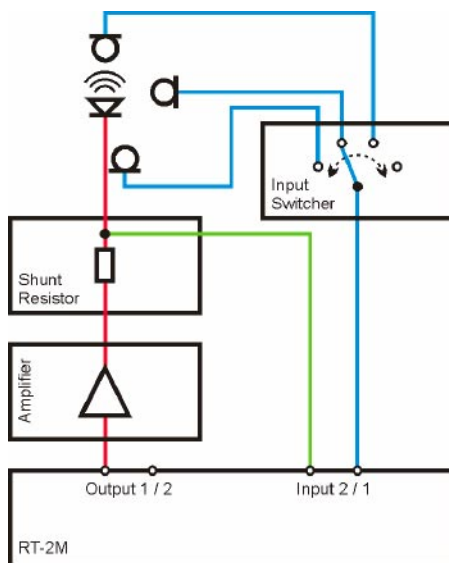

Pic. 1-1 Test setup with 1 speaker, 3 mics (3-in-1 operation)

1.2.2 Stereo device testing

Typical DUTs are stereo headphones or TV sets.

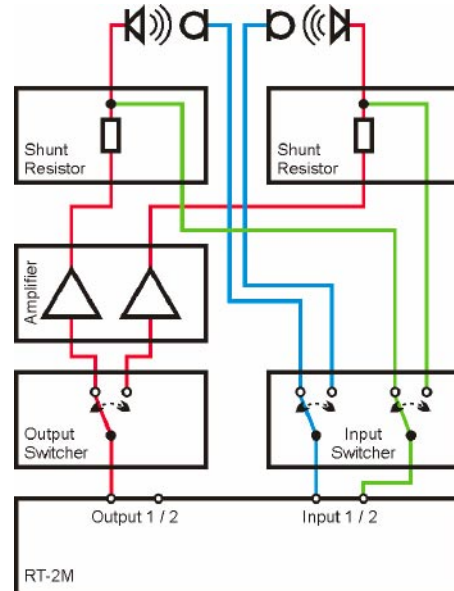

Pic. 1-2 Stereo test setup (2x 2-in-1 operation)

1.2.3 One analyzer for several test jigs

This setup can be found e.g. at

- parallel production of identical DUTs,
- multi-channel DUTs (e.g. 3-way speakers)

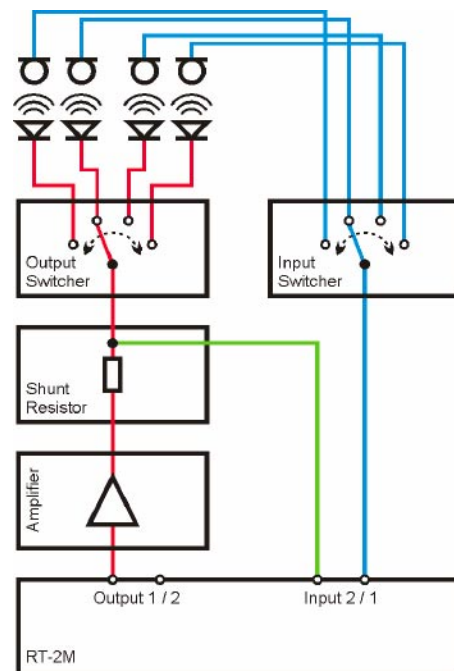

Pic. 1-3 Test setup with 4-channel device (4-in-1 operation)

2 System setup

2.1 Control interface

The (root) switcher must be connected to the controller PC through the USB interface. Connecting more switchers to the controller PC can be done in two different ways.

- i) All switchers are linked to the controller PC via individual USB cables,
- ii) Only the root switcher is connected to the controller PC via USB, whereas the other switchers are linked to the root switcher in a 'daisy chain' via RS485.

2.2 Address assignment

Every switcher that is connected to the controller PC via USB interface must have an individual address ('Unit Ident'). Cascading up to 8 pcs. input or output switchers via an USB port is possible via RS485 daisy chain.

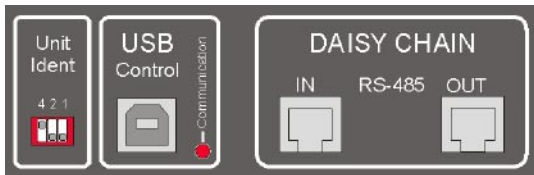

Pic. 2-1 Unit ID DIP-switch, USB & RS485 interface

- ⇒ **Maximum 16 pcs. switchers (8*input + 8*output) can be connected to one PC.**
- ⇒ **Every input or output switcher in the same daisy chain must have an individual address '0...7'.**
- ⇒ **If two 'root' switchers are linked to the PC via separate USB interfaces, the addresses '0...7' can be assigned independently within the respective daisy chains.**
- ⇒ **If max. 8 pcs. input or output switchers are connected to a PC, each of them must have a different address (recommended).**

NOTE The unit must be switched OFF & ON again after changing the address.

Case a)

- One root switcher → USB #1 of PC
- Additional input or output switchers → daisy chain of root switcher

Case b)

- 1st root switcher → USB #1 of PC
- 2nd root switcher → USB #2 of PC
- Additional input or output switchers → separate daisy chains of root switchers.

Case c)

- Several switchers → separate USBs of PC

Case a)

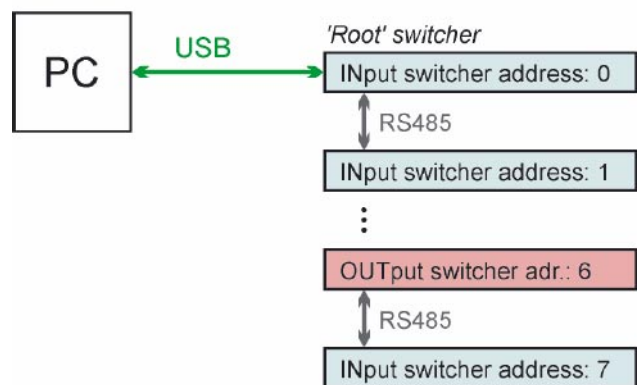

Case b)

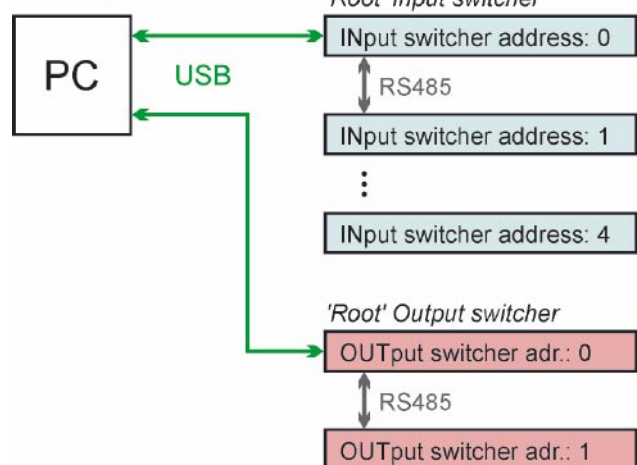

Case c)

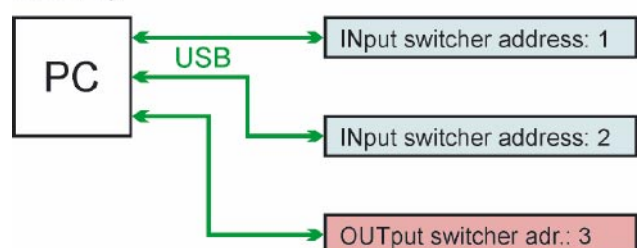

Pic. 2-2 Cascade examples

3 Functional description

3.1 Power supply

The internal IS1002 electronics are powered by a built-in supply that can be plugged directly to AC mains voltage (85–260 VAC, 50/60 Hz).

3.2 2*5:2 vs. 10:1 operation

The 10 input channels can be linked to one or two separate output connectors in two different ways.

a) '2*5:2' operation, i.e.

- one connector of input group A is linked to an output (group A or B), and
- one connector of input group B is linked to another output (group B or A).

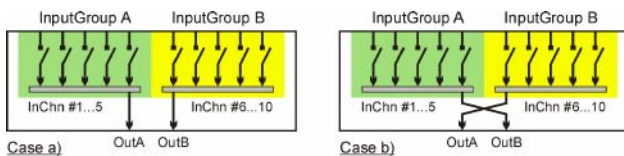

Pic. 3-1 2*5:2 operation

b) '10:1' operation: one input connector (group A or B) is linked to one output.

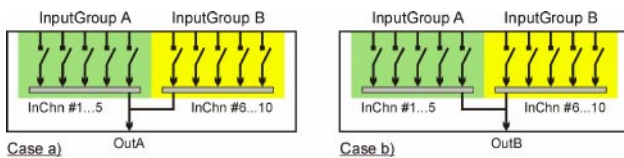

Pic. 3-2 10:1 operation

3.3 LEDs

The LEDs on the front panel indicate the status of input and output connectors.

- **Green** = input linked to output **A**,
- **Red** = input linked to output **B**.

The single red LED on the rear panel lights up every time the controller PC is communicating with the input switcher.

3.4 Microphone power

Phantom or ICP® power supply can be activated individually via remote control on every input connector.

- 2 V Phantom (5 V upon request),
- 48 V Phantom,
- ICP®.

3.5 Ground lift

Pin1 (shield) of all XLR input & output connectors are permanently linked together. The 'Lift' switch on the front panel

- connects this link to earth (i.e. grounded),
- disconnects it from ground (i.e. floating).

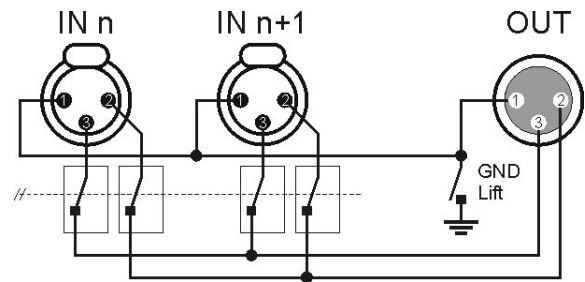

Pic. 3-3 Pin 1 grounding

3.6 Cascading via daisy chain

Up to 8 input switchers can be linked to a daisy chain via their RS485 interfaces. In this mode, a PC can control the switchers via one USB port.

Link the switchers together by using a RJ-11 cable with minimum 4 pins that are connected 1:1.

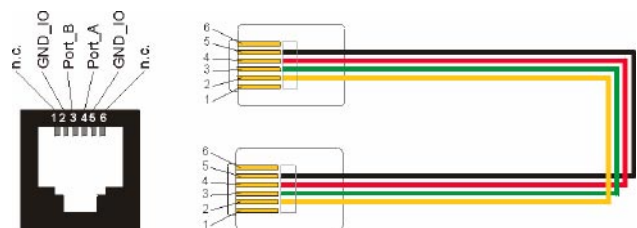

Pic. 3-4 RJ-11 cable

3.7 Rack mounting

Attach the rack mount wings to the left, right side of the input switcher by using 6 pcs. M3*6 mm screws.

4 Operation

4.1 Control elements

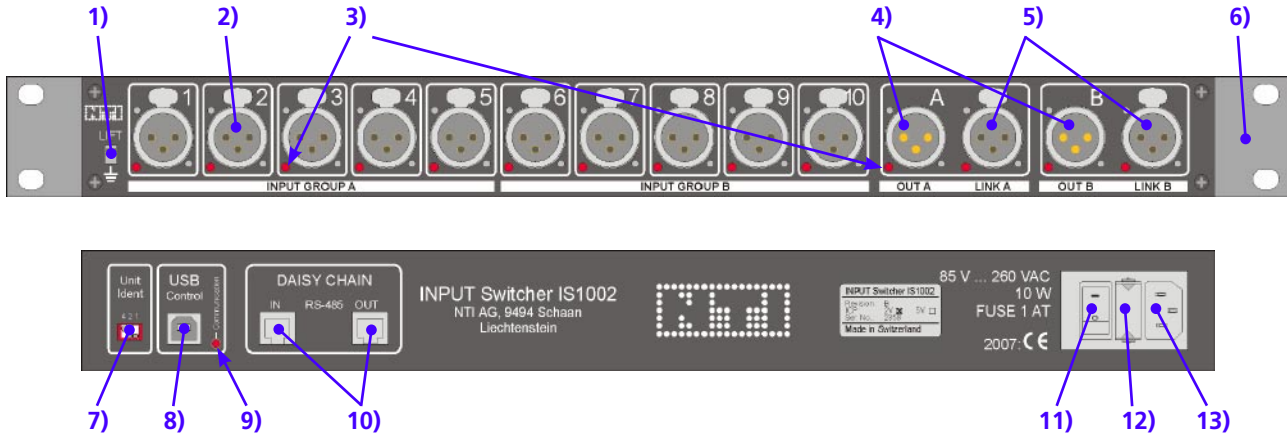

Pic. 4-1 IS1002 front- & rearpanel

1) Ground lift switch

Connects / disconnects the XLR pins 1 to / from ground (refer to *chapter 3.5*).

- Upper position → XLR pin 1 (shield) disconnected from ground
- Lower position → XLR pin 1 connected to ground.

2) 10 pcs. XLR female input connectors

Input connectors of group A and B that can be linked to an output connector.

3) XLR connector LEDs

The dual-color LEDs indicate the status of the corresponding XLR connectors (see also *Pic. 4-3*).

- **Green** = input linked to output **A**,
- **Red** = input linked to output **B**.

4) Output connector

The output connectors A, B can be linked individually to an input connector.

5) Link connectors

If two or more input switchers are cascaded, the output connector of switcher $n+1$ must be linked to the link connector of switcher n (*Pic. 4-2*).

6) Rack mount wings

7) DIP-switch for USB address

Adjust the DIP-switch of every IS1002 connected to the controller PC according to the rules given in *chapter 2.2*.

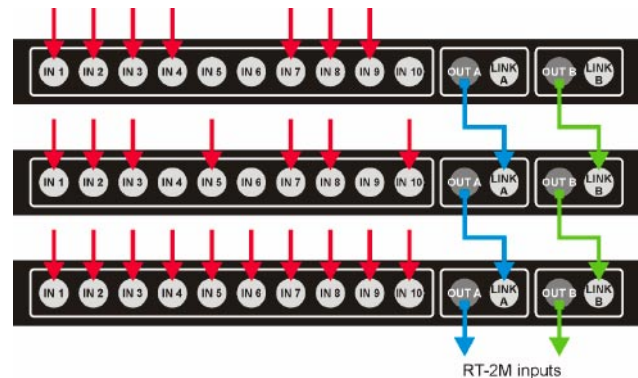

Pic. 4-2 Cascade setup

8) USB connector

9) USB communication LED

LED lights up as soon as any communication is active between the IS1002 and the controller PC.

10) RS485 connectors

Establish the communication to the switchers in a daisy chain by plugging in RJ-11 cables to the corresponding RS485 connectors.

11) On/Off switch

Adjust the USB address before switching ON the IS1002.

12) Mains fuse

The IS1002 requires a mains fuse 250 V, 1 AT.

13) AC mains connector

Mains power rating is 85–260 VAC.

4.2 Control software

The "NTI GP-IO Tool" software allows monitoring & manually controlling the switcher status.

4.2.1 Installation

- Open the folder "NTI GP-IO Tool → Install V1.0"
- Double-click on "setup.exe" and execute the given instructions.
- Run "NTI GP-IO Tool".

4.2.2 Operation

1) File menu

Allows to saving & loading user-defined switcher settings to / from a file.

- Select menu "File → Save setup to file" to save the current switcher settings under a user-defined name on the controller PC.
- Select menu "File → Load setup from file" to activate previously stored settings.

2) 2*5:2, 10:1 mode

Mark the corresponding radio button to select the required operation mode (refer to *chapter 3.2*).

3) Virtual COM-port

Indicates the number of the virtual COM-port for the corresponding switcher.

4) Serial-#

Indicates the switcher's serial number.

5) Version

Indicates the switcher's actual firmware version.

6) DIP-switch ID

Indicates the status of the DIP-switch during the last power-up and the corresponding unit ID, i.e. USB address (refer to *chapter 2.2*).

7) Input connectors

To activate / deactivate an input connector (i.e. link / disconnect it to / from an output connector),

- click on the required connector *or*
- click on the connector's LED *or*
- press the corresponding function key <F1> .. <F10> on your keyboard.

8) Microphone power

To switch on the microphone power on an input connector,

- click on the selector field and
- click on the required entry in the list.

9) Internal links

The two black lines visualize the currently active electrical link(s) between the input and output connectors.

10) LEDs

The green and red LEDs indicate the input and output connectors that are currently linked.

11) Routing

Click on this button to swap between

- "Normal Routing": connector of input group A → output connector A, connector of input group B → output connector B.
- "Swapped Routing": connector of input group A → output connector B, connector of input group B → output connector A.

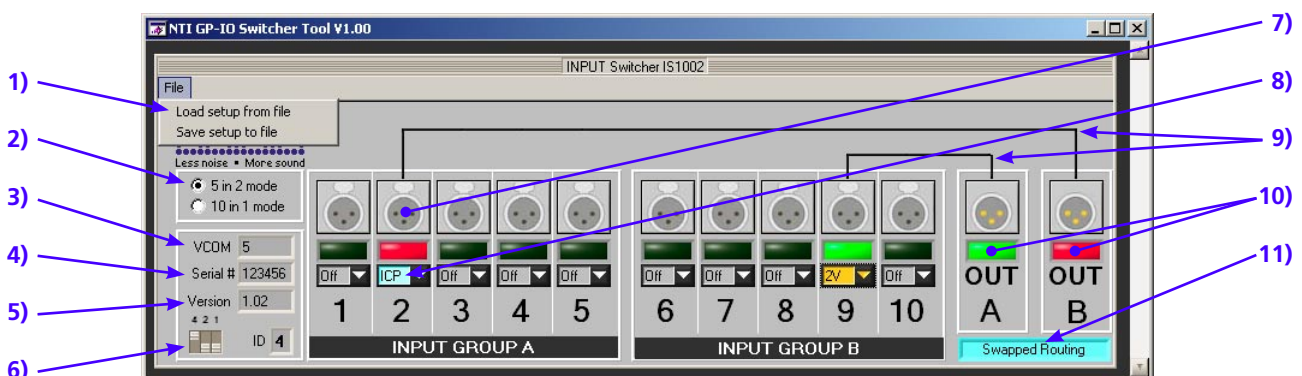

Pic. 4-3 NTI GP-IO Switcher Tool screenshot



5 Technical specifications

5.1 Electrical

No. of input channels.....	10
No. of output channels	2 (supports 2*5:2 or 10:1 operation)
Max. input current.....	2 A
Max. input voltage.....	46.7 Vp
Mic power supply	48 V Phantom 2 V Phantom (optional 5 V upon request) ICP®
Crosstalk @ 20 kHz	
Phantom OFF, 48 V.....	-140 dB
Phantom 2 V or ICP®	-125 dB
Shunt capacitance pin 2, 3 → 1	< 50 pF
Initial series resistance	typ. < 0.4 Ohm
Maximum relay switching power	
Recommended	≤ 5 W
Limit.....	≤ 30 W (1 A)
USB interface	1.1, communication with PC
RS485 interface	Daisy chain cascading of up to 8 pcs. IS1002, connected via RJ-11 cable (4 or 6 pins 1:1); controlled via an USB interface
Mains power.....	85–260 VAC, 50 / 60 Hz
Fuse rating.....	1 A / 250 V slow

NOTE High switching power accelerates the relay degradation.

5.2 Mechanical

Dimensions WxHxD (without rack wings)	425 x 45 x 160 mm
Weight	1.4 kg
Operating conditions.	0–45°C / 90% R.H.

ICP® is a registered trademark of PCB Piezoelectronics