

Less noise • More sound

User's Guide

Audio Output Switcher OS-0210



Document V 2.0.0 / 0e
Related to Firmware V2.0.0



*NTI is an ISO 9001
certified company*



Table of contents

Scope	3
Declaration of Conformity	3
CE / FCC compliance statement.....	3
Disposal and recycling	
Warranty conditions	
International warranty	
Limitations	
Repairs	
1 Introduction	4
1.1 Overview	4
1.2 Applications.....	4
1.2.1 Multi-speaker testing with one mic.....	4
1.2.2 Stereo device testing	4
2 System setup	5
2.1 Control interface	5
2.2 Address assignment.....	5
3 Functional description	6
3.1 Power supply	6
3.2 2*2:5 vs. 1:10 operation.....	6
3.3 LEDs	6
3.5 Ground lift.....	6
3.6 Cascading via daisy chain.....	6
3.7 Rack mounting	6
4 Operation	7
4.1 Control elements	7
4.2 Control software.....	8
4.2.1 Installation	8
4.2.2 Operation.....	8
5 Technical specifications	9
5.1 Electrical	9
5.2 Mechanical	9



Scope

This document describes the installation and general operation of the OS-0210 output switcher. Programming related information can be found in the "OS-0210 Developer's Guide".

NOTE The PC-software tunkey solutions from NTI (e.g. RT-Speaker) already comprise the automated control of connected output switcher(s).

Declaration of Conformity

CE / FCC compliance statement

We, the manufacturer

NTI AG

Im alten Riet 102

9494 Schaan

Liechtenstein, Europe

hereby declare that the output switcher OS-0210, approved in 2008, complies with the following standards or other standard documents.

1 Introduction

1.1 Overview

OS-0210 is an advanced, multi-functional audio output switcher that offers the following key features.

- 2 input and 10 output channels for 2*2:5 or 1:10 operation,
- Individual channel status indication via two-color LEDs,
- Ground lift,
- Remote controlled via USB,
- Cascading of up to 8 output switchers via RS485 daisy chain supported,
- .NET assembly.

1.2 Applications

The following chapters provide a rough overview on typical applications for the OS-0210 output switcher.

1.2.1 Multi-speaker testing with one mic

This setup is typically used for speaker cabinet testing, where e.g. a tweeter, mid-range driver and woofer must be verified via one microphone.

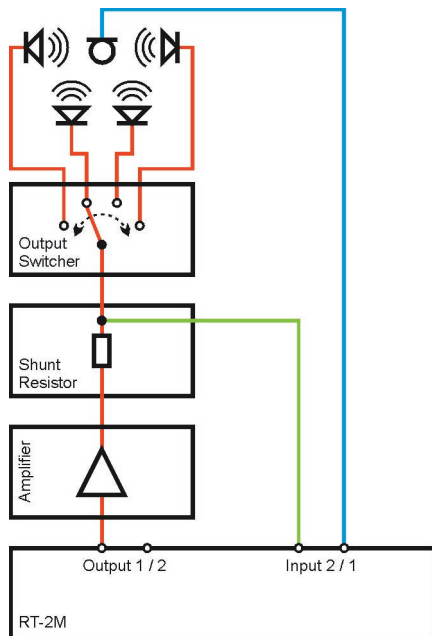

Pic. 1-1 Test setup with 4 speakers, 1 mic (1:4 operation)

1.2.2 Stereo device testing

Typical DUTs are stereo headphones or TV sets.

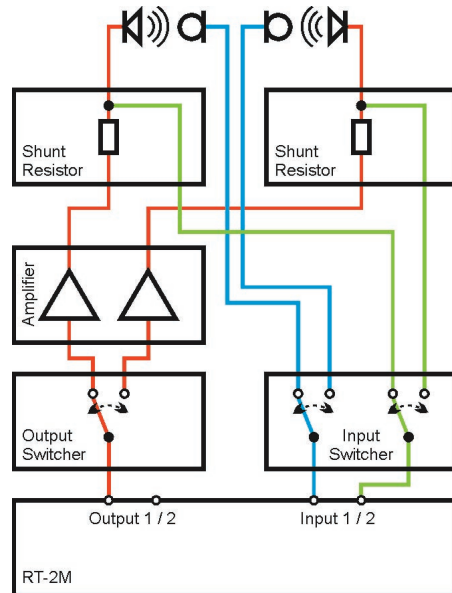

Pic. 1-2 Stereo test setup (OS-0210 in 1:2 operation)

2 System setup

2.1 Control interface

The (root) switcher must be connected to the controller PC through the USB interface. Connecting more switchers to the controller PC can be done in two different ways.

- i) All switchers are linked to the controller PC via individual USB cables,
- ii) Only the root switcher is connected to the controller PC via USB, whereas the other switchers are linked to the root switcher in a 'daisy chain' via RS485.

2.2 Address assignment

Every switcher that is connected to the controller PC via USB interface must have an individual address ('Unit Ident'). Cascading up to 8 pcs. output or input switchers via an USB port is possible via RS485 daisy chain.

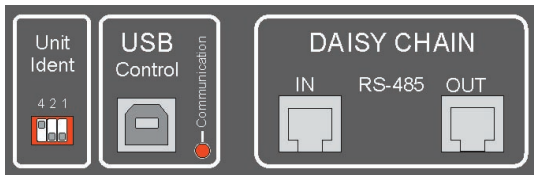

Pic. 2-1 Unit ID DIP-switch, USB & RS485 interface

- ⇒ **Maximum 16 pcs. switchers (8x output + 8x input) can be connected to one PC.**
- ⇒ **Every output, input switcher in the same daisy chain must have an individual address '0...7'.**
- ⇒ **If two 'root' switchers are linked to the PC via separate USB interfaces, the addresses '0...7' can be assigned independently within the respective daisy chains.**
- ⇒ **If max. 8 pcs. output, input switchers are connected to a PC, each of them must have a different address (recommended).**

NOTE The unit must be switched OFF & ON again after changing the address.

Case a)

- One root switcher → USB #1 of PC
- Additional output or input switchers → daisy chain of root switcher

Case b)

- 1st root switcher → USB #1 of PC
- 2nd root switcher → USB #2 of PC
- Additional output or input switchers → separate daisy chains of root switchers.

Case c)

- Several switchers → separate USBs of PC

Case a)

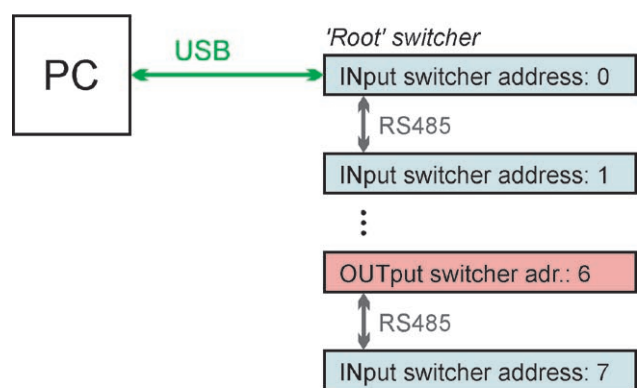

Case b)

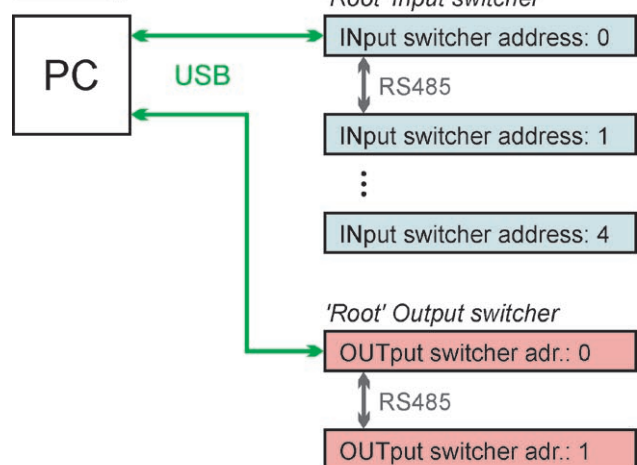

Case c)

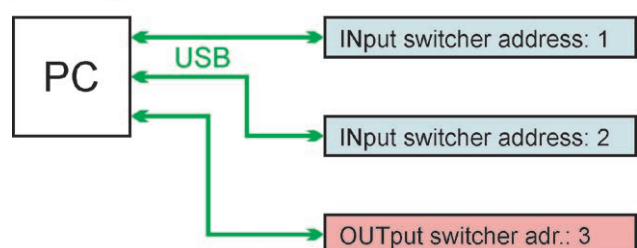

Pic. 2-2 Cascade examples

3 Functional description

3.1 Power supply

The internal OS-0210 electronics are powered by a built-in supply that can be plugged directly to AC mains voltage (85–260 VAC, 50/60 Hz).

3.2 2*2:5 vs. 1:10 operation

The two input channels can be linked to the 2*5 or 10 separate output connectors in two ways.

2:5 operation, i.e.

- a) an input connector (A or B) is linked to an output connector of group A, *and/or*
- b) the other input connector (B or A) is linked to an output connector of group B.

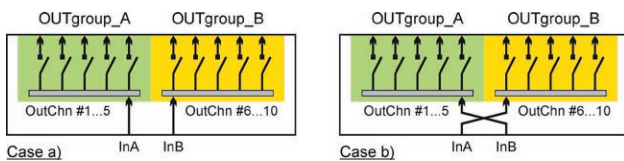

Pic. 3-1 2:5 operation

1:10 operation, i.e. an input connector (A or B) is linked to an output connector of group A or B.

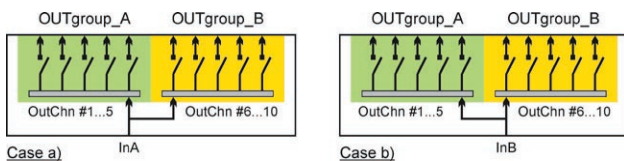

Pic. 3-2 1:10 operation

3.3 LEDs

The LEDs on the front panel indicate the status of output and input connectors.

- **Green** = output linked to input **A**,
- **Red** = output linked to input **B**.

The single red LED on the rear panel lights up every time the controller PC is communicating with the input switcher.

3.5 Ground lift

Pin 1 (shield) of all XLR input & output connectors are permanently linked together. The 'Lift' switch on the front panel either

- connects this link to earth (grounded) *or*,
- disconnects it from ground (floating).

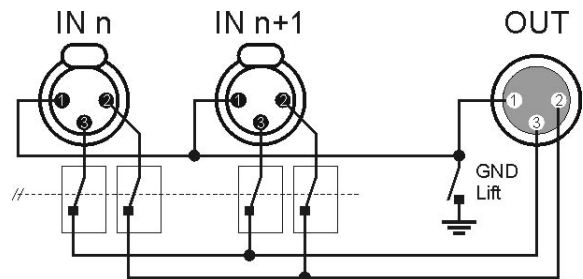

Pic. 3-3 Pin 1 grounding

3.6 Cascading via daisy chain

Up to 8 output switchers can be linked in a daisy chain via their RS485 interfaces. In this mode, a PC can control the switchers via one USB port. Link the switchers together by using an RJ-11 cable with minimum 4 pins that are connected 1:1.

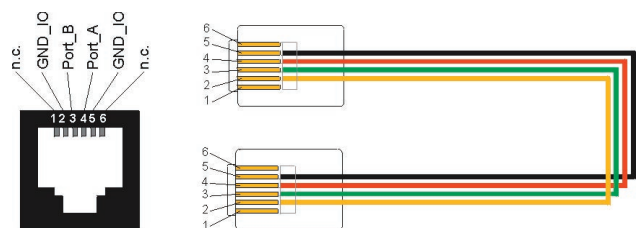

Pic. 3-4 RJ-11 cable

3.7 Rack mounting

Attach the two rack mount wings to the left, right side of the OS-0210 by using 6 pcs. M3 x 6 mm screws.

4 Operation

4.1 Control elements

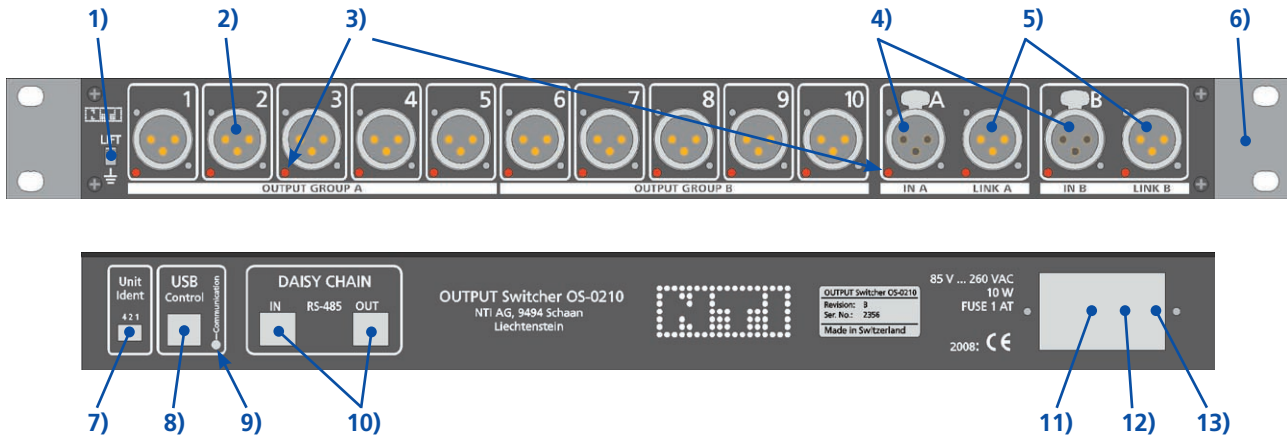

Pic. 4-1 OS-0210 front- & rearpanel

1) Ground lift switch

Connects / disconnects the XLR pins 1 to / from ground (refer to *chapter 3.5*).

- Upper position → XLR pin 1 (shield) disconnected from ground
- Lower position → XLR pin 1 connected to ground.

2) 10 pcs. XLR male output connectors

Output connectors of group A and B that can be linked to an input connector.

3) XLR connector LEDs

The dual-color LEDs indicate the status of the corresponding XLR connectors (see also *Pic. 4-3*).

- **Green** = output linked to input **A**,
- **Red** = output linked to input **B**.

4) Input connectors

The input connectors A, B can be linked individually to an output connector.

5) Link connectors

If two or more output switchers are cascaded, the input connector of switcher $n+1$ must be linked to the link connector of switcher n (*Pic. 4-2*).

6) Rack mount wings

7) DIP-switch for USB address

Adjust the DIP-switch of every OS-0210 connected to the controller PC according to the rules given in *chapter 2.2*.

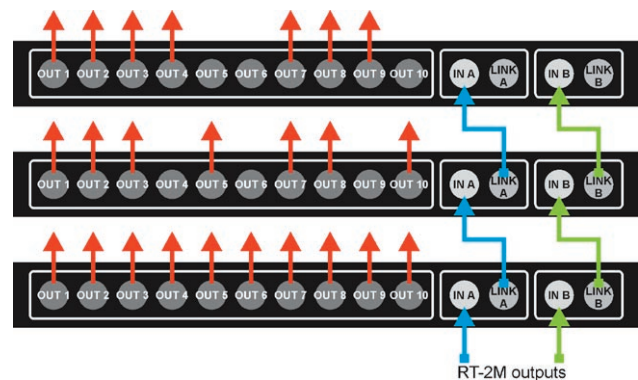

Pic. 4-2 Cascade setup

8) USB connector

9) USB communication LED

LED lights up as soon as any communication is active between the OS-0210 and the controller PC.

10) RS485 connectors

Establish the communication to the switchers in a daisy chain by plugging in RJ-11 cables to the corresponding RS485 connectors.

11) On/Off switch

Adjust the USB address before switching ON the OS-0210.

12) Mains fuse

The OS-0210 requires a mains fuse 250 V, 1 AT.

13) AC mains connector

Mains power rating is 85 – 260 VAC.

4.2 Control software

The "NTI GP-IO Tool" software allows monitoring & manually controlling the switcher status.

4.2.1 Installation

- a) Open the folder "NTI GP-IO Tool → Install Vx.y"
- b) Double-click on "setup.exe" and execute the given instructions.
- c) Run "NTI GP-IO Tool".

4.2.2 Operation

1) File menu

Allows to saving & loading user-defined switcher settings to / from a file.

- Select menu "File → Save setup to file" to save the current switcher settings under a user-defined name on the controller PC.
- Select menu "File → Load setup from file" to activate previously stored settings.

2) 2:5, 1:10 mode

Mark the corresponding radio button to select the required operation mode (refer to *chapter 3.2*).

3) Virtual COM-port

Indicates the number of the virtual COM-port for the corresponding switcher.

4) Serial-#

Indicates the switcher's serial number.

5) Version

Indicates the switcher's actual firmware version.

6) DIP-switch ID

Indicates the status of the DIP-switch during the last power-up and the corresponding unit ID, i.e. USB address (refer to *chapter 2.2*).

7) Output connectors

To activate / deactivate an output connector (i.e. link / disconnect it to / from an input connector),

- click on the required connector *or*
- click on the connector's LED *or*
- press the corresponding function key <F1> .. <F10> on your keyboard.

8) Internal links

The two black lines visualize the currently active electrical link(s) between the input and output connectors.

9) LEDs

The green and red LEDs indicate the input and output connectors that are currently linked.

10) Routing

Click on this button to swap between

- "Normal Routing": connector of input group A → output connector A, connector of input group B → output connector B.
- "Swapped Routing": connector of input group A → output connector B, connector of input group B → output connector A.

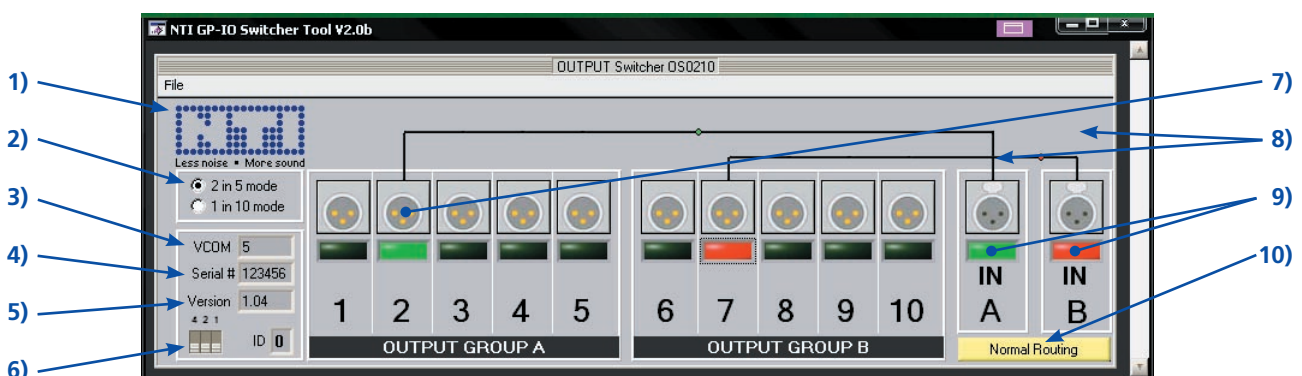

Pic. 4-3 NTI GP-IO Switcher Tool screenshot



5 Technical specifications

5.1 Electrical

No. of input channels.....	2
No. of output channels	10 (allows 2*2:5 or 1:10 operation)
Max. input current.....	6 A
Max. input voltage.....	46.7 Vp
Crosstalk @ 20 kHz.....	-140 dB
Shunt capacitance pin 2,3 → 1	< 50 pF
Initial series resistance	typ. < 0.4 Ohm
Maximum relay switching power	
Recommended	≤ 5 W
Limit.....	≤ 30 W (6 A)
USB interface	1.1, communication with PC
RS485 interface	Daisy chain cascading of up to 8 pcs. OS-0210, connected via RJ-11 cable (4 or 6 pins 1:1); controlled by one USB interface
Mains power.....	85...260 VAC, 50 / 60 Hz
Fuse rating.....	1 A / 250 V slow

NOTE High switching power accelerates the relay degradation.

5.2 Mechanical

Dimensions WxHxD (without rack wings)	425 x 45 x 160 mm (19", 1 rack unit high)
Weight	1.4 kg
Operating conditions.	0...45°C / 90% R.H.