

INTRODUCTION

The plug-on measurement microphones M4260 or M2210 form together with the XL2 a comprehensive sound level meter and acoustic analyzer. The microphones are 48 VDC phantom powered and include an electronic data sheet.

Integrated Preamplifier

The microphone bodies contain the pre-amplifier and require 48 VDC phantom power supply for operation. They combine high dynamic range and wide frequency range with low noise. The measurement microphones can also be connected with the ASD Cable to the XL2 Audio and Acoustic Analyzer for measurements at remote locations or reducing acoustical reflections.

ELECTRONIC DATA SHEET

The M4260 and M2210 measurement microphones include an electronic data sheet. The automated sensor detection (ASD) of the XL2 Analyzer reads this data sheet, enabling the XL2 to automatically recognize the microphone model, sensitivity and calibration data. This ensures correct measurement results using the M4260 or M2210 microphones.

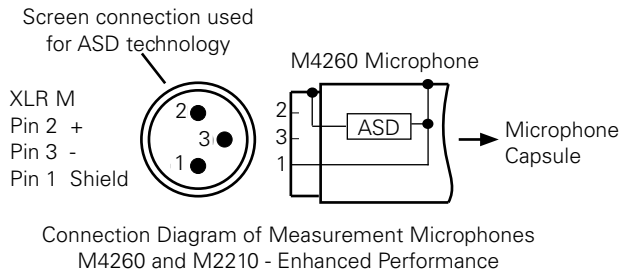

CONNECTING TO XL2

Microphone plugs directly to the XL2

The XL2 automatically reads ASD electronic data sheet of the connected microphone as follows:

- Connect the measurement microphone to the XL2.
- Switch on the XL2 with the on/off button.
- The XL2 reads the electronic data sheet of the connected microphone during a short initialization process prior the first measurement.

Microphone Connection via the ASD Cable

The measurement microphones M4260 and M2210 can be connected with the ASD Cable to the XL2 Audio and Acoustic Analyzer for measurements at remote locations or reducing acoustical reflections. The ASD Cable includes a separate line for transmitting the electronic data sheet to the XL2, thus not affecting the measurement data.

The electronic data sheet is transmitted via the XLR connector's housing and the shield lead of the ASD Cable. Do not touch these parts during the short initialization period to ensure the complete data sheet is recognized by the XL2. The automated sensor detection does not disturb any measurements. You may chain up to 4x ASD Cables together in tandem. The ASD technology supports accurate data communication up to a length of 20 meters (= 65 feet).

Microphone Connection via a professional Audio Cable

For distances longer than 20 meter (= 65 feet) use a high quality, low capacitance standard professional audio cable. In this scenario, no separate data line for the transmission of the electronic data sheet is available, thus the microphone sensitivity has to be entered manually into the XL2 Analyzer.

SPECIFICATIONS

	M4260	M2210 - Enhanced Performance
Microphone Type	Omni-directional, pre-polarized condenser, free field microphone	
Capsule / Transducer	1/4" permanently installed capsule	1/2" detachable capsule with 60UNS2 thread
Preamplifier type	-	MA220
Flatness	Class 2 (IEC61672-1) +1/-4.5 dB @ 5 Hz - 20 Hz ±1.5 dB @ 20 Hz - 4 kHz ±4.5 dB @ 4 kHz - 20 kHz	Class 1 (IEC61672-1) ±1 dB @ 5 Hz - 20 Hz ±1 dB @ 20 Hz - 4 kHz ±2 dB @ 4 kHz - 20 kHz
Frequency Range	5 Hz - 20 kHz	5 Hz - 20 kHz
Residual Noise Floor typ.	29 dB(A)	19 dB(A)
Linear Measurement Range with XL2	35 dB(A) - 144 dB acc. IEC 60804	28 dB(A) - 144 dB acc. IEC 60804
Maximum SPL @ THD 3%, 1 kHz	144 dB SPL	144 dB SPL
Sensitivity typical	-31.7 dBV/Pa ±4 dB (26 mV/Pa) @ 1kHz	-34 dBV/Pa ±3 dB (20 mV/Pa) @ 1kHz
Temperature Coefficient	±0.02 dB /°C @ -10°C to +50°C (14°F to 122°F)	±0.015 dB/°C @ -10°C to +50°C (14°F to 122°F)
Pressure Coefficient	not defined	-0.02 dB / kPa
Influence of Humidity	not defined	< ±0.01 dB (non condensing)
Long Term Stability	not defined	> 250 years / dB
Temperature Range	-10°C to +50°C (14°F to 122°F)	
Humidity	5% to 90% RH, non condensing	
Electronic Data Sheet	NTi Audio ASD according IEEE P1451.4 V1.0, Class 2, Template 27	
Output Impedance	100 Ohm balanced	
Power Supply	48 VDC phantom power, 3 mA typical	
Dimensions	Length 150 mm (5.9"), diameter 20.5 mm (0.8")	
Connector	Balanced 3-pole XLR	
NTi Audio #	600 040 025	600 040 025

CALIBRATION & SERVICE

The M4260 and M2210 measurement microphones are recommended to be calibrated at yearly intervals. A detailed calibration certificate will be issued following the standards EN ISO / IEC 17025. For service and calibration follow the guidelines at www.nti-audio.com/service.

ACCESSORIES

Calibration Certificate

Individual and detailed calibration certificate
NTi Audio #: 600 000 018

Precision Calibrator 94/114 dB, Class 1

The precision calibrator ensures accurate sound level measurements. It generates 94 or 114 dB SPL reference tones @ 1 kHz for calibration of 1/2" and 1/4" measurement microphones (compatible to all NTi Audio microphones).
NTi Audio #: 600 000 390

ASD Cable

The ASD Cable allows for extended connections of the measurement microphones M4260 or M2210, while maintaining the automated sensor detection functionality. You may chain up to 4x ASD Cables together in tandem. Length = 5 meter (16 ft).
NTi Audio #: 600 000 336

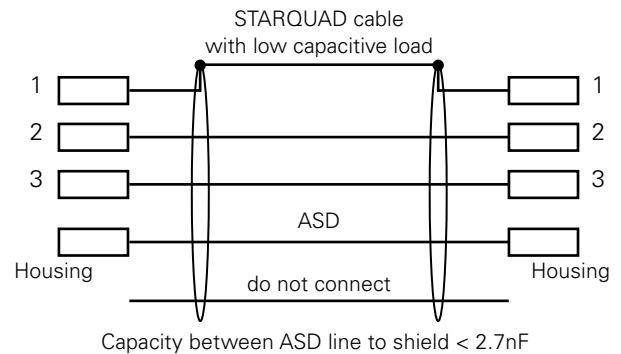

Warranty Terms

NTi Audio guarantees the measurement microphone and its components against defects in material or workmanship for a period of one year from the date of original purchase. Read the full warranty terms at www.nti-audio.com.

TYPICAL FREQUENCY RESPONSE

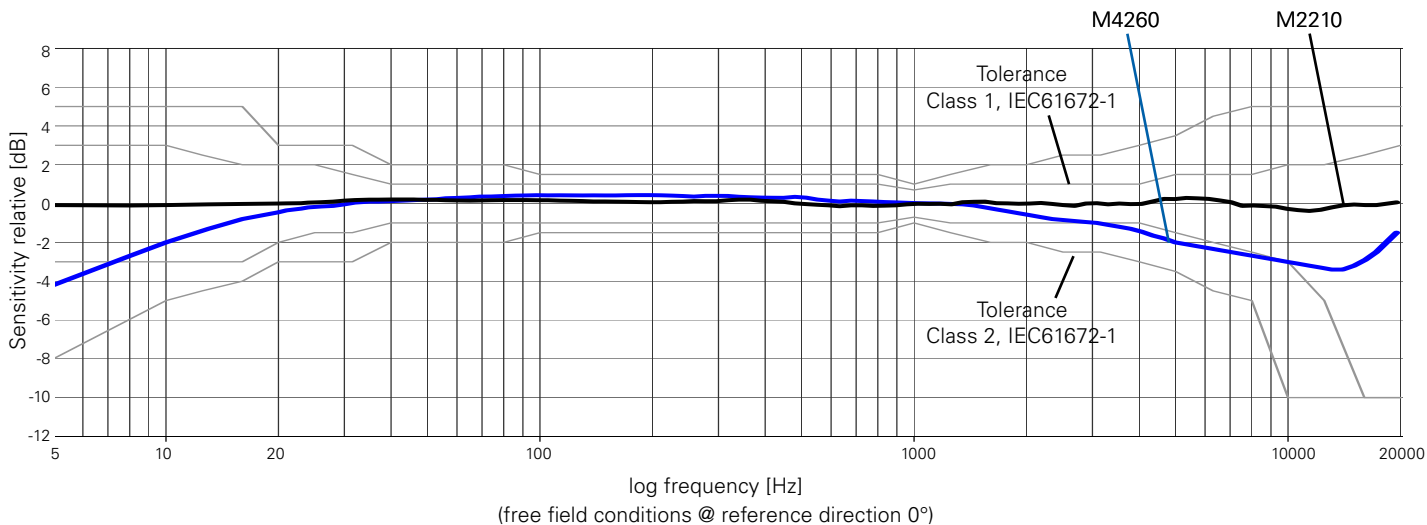

GENERAL

Content

- M4260 or M2210 Measurement Microphone
- Product Data
- Pouch, NTi Audio #: 600040030
- 1/4" Windscreen, NTi Audio #: 150000024
or 1/2" Windscreen, NTi Audio #: 150000025
- Microphone-holder + Adapter 5/8" - 3/8"
NTi Audio #: 160000039

Notes

- Use the microphone for the intended purpose only.
- Protect the microphone from contamination by always using the supplied windscreen.
- Never use the microphone in a damp or wet environment.
- Do not jar or drop the microphone.
- Do not remove the microphone protective grid.
- Do not touch the microphone membrane.

NTi AUDIO WORLDWIDE

NTi Audio AG

Im alten Riet 102
9494 Schaan
Liechtenstein, Europe
Tel.: +423 239 6060
Fax: +423 239 6089
info@nti-audio.com

NTi Americas

PO Box 231027
Tigard, Oregon 97281
USA
Tel.: +1 503 684 7050
Fax: +1 503 684 7051
americas@nti-audio.com

NTi China

Room 722, 7F, Building 6-3A,
No 1388, Bin He Rd.
215000 Suzhou, China
Tel.: +86 512 6802 0075
Fax: +86 512 6802 0097
china@nti-audio.com

NTi Japan

Ryogokusakamoto Bld. 1-8-4
Ryogoku, 130-0026 Sumida-Ku
Tokyo, Japan
Tel.: +81 3 3634 6110
Fax: +81 3 3634 6160
japan@nti-audio.com

All information subject to change without notice.
M4260, M2210 and XL2 are trademarks of NTi Audio AG.