



*MR-PRO measures cables with pin 1 failures*

The Minirator MR-PRO generates audio test signals for commissioning and servicing of audio installations. Additionally it measures the impedance of connected devices, of 70V/100V speaker systems and audio cables. This application notes describes the cable testing feature including verification of any false pin1 connection to the cable shield.

The MR-PRO features a cable test function that quickly detects bad or wrongly terminated XLR cables. The test is based on an impedance measurement.

## 1. Cable test for 1:1 wiring

The cable test function detects the 1:1 connection of XLR cables by adding two different resistances at the cable end (1 kOhm and 2 kOhm resistance). In case the impedance measurement finds the expected resistance values then the MR-PRO indicates "OK" for a proper 1:1 connection.

### Measurement Guideline

- Connect one cable end to the MR-PRO output connector and the other end to the MR-PRO cable test input or alternatively utilize the NTI Cable Test Adapter for permanently installed cables.
- Select the MR-PRO measurement function "CABLETEST". The displayed test result shall be "OK" (= all pins are connected to the same pin at the other end).



*Cable Test Adapter*

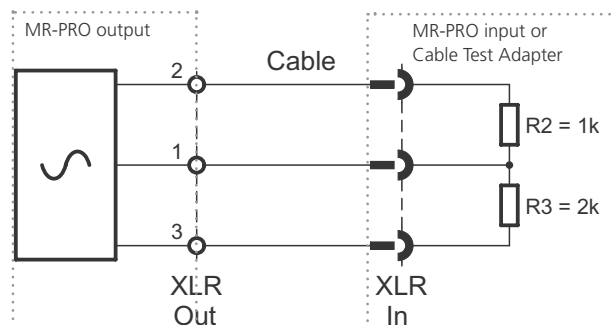

*MR-PRO cable testing by measuring the impedance*

## Sample Test Results displayed on the MR-PRO Screen

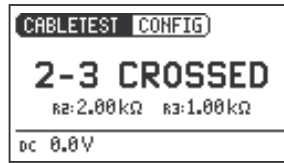

The tested cable is defective, the pins 2 and 3 are crossed. Other error indications may appear depending on the cables fault.



The tested cable is OK.

*MR-PRO test results*



*Test results of a 5m audio cable with pin1 failure*

## 2. Cable test for pin1 detection

Imagine you assemble a standard 3-pin XLR cable, but accidentally solder the cable shield to pin 2 and the hot wire to pin 1 on both sides. This cable is commonly analyzed by all cable testers as “OK”, as all pins are 1:1 connected, but the MR-PRO detects such assembly problems.

### How can a wrongly connected shield be detected?

A good XLR cable is a nearly perfect balanced device. For most audio cables the capacities between pin2 – pin1 and pin3 – pin1 will differ less than 5%. Differences higher than 10% are possible indications of a shielding fault. Differences exceeding 25% confirm an unbalanced cable, caused by a wrongly assembled shield.

### Measurement Guideline

- Connect the cable to the MR-PRO output and leave the second end open (=not connected).
- Select the MR-PRO measurement function “IMPEDANCE” and adjust test level = 0 dBu and frequency = 10 kHz.
- Select “RL” in the bottom line, showing the detailed impedance results of pin 2 and pin 3.
- Any impedance measurement result with a deviation of more than 10% indicates already a possible pin 1 assembly problem.

## Measurement Hints:

The MR-PRO supports impedance measurements up to 50 kOhm with the individual impedances up to 25 kOhm at pin 2 and 3. This measurement range ensures accurate test results according the generator specifications. This measurement range allows detecting wrongly connected shields for audio cables longer than 3 meters.

For shorter cables with an impedance above the measurement range you may extend the cable under test with a good XLR-cable of approx. 2 meter length, thus reducing the total cable impedance into the MR-PRO measurement range.