

OPERATING MANUAL
MEASUREMENT MICROPHONES

Version: V 2.0 - 2026-05-05

Table of Contents

1 Overview

1.1 Measurement Microphones	<u>6</u>
1.2 Outdoor Measurement Microphones	<u>8</u>
1.3 Microphone Preamplifiers	<u>9</u>
1.4 Scope of Delivery	<u>10</u>

2 Description

2.1 Integrated PreAmplifier	<u>14</u>
2.2 Electronic Data Sheet	<u>14</u>
2.3 Connecting to XL2 or XL3	<u>15</u>
2.3.1 Microphone plugs directly into the XL2 or XL3	<u>15</u>
2.3.2 Microphone Connection via the ASD Cable	<u>15</u>
2.3.3 Microphone Connection via a professional Audio Cable	<u>16</u>

3 WP40 Outdoor Measurement Microphones

3.1 Outdoor Measurement Microphones Class 1 / Type 1 certified	<u>19</u>
3.2 WP40 Assembling	<u>19</u>
3.2.1 Install WP-ASD Cable	<u>20</u>
3.2.2 Insert Measurement Microphone	<u>21</u>
3.2.3 Attach the Microphone to the Upper Body Tube	<u>22</u>
3.2.4 Assemble the Weather Protection Body	<u>24</u>

3.2.5 Mount the Top Section	<u>25</u>
3.2.6 WP40 Disassembling the Top Section	<u>26</u>
3.2.7 WP40 with Dehumidifier	<u>27</u>
3.2.8 WP40 Maintenance	<u>31</u>
3.2.9 Handle Wind Screen with Care	<u>33</u>
4 WP30 Outdoor Measurement Microphones (Legacy)	
4.1 WP30 Assembling	<u>35</u>
4.1.1 Install ASD Cable	<u>35</u>
4.1.2 Insert Measurement Microphone	<u>36</u>
4.1.3 Attach the Microphone to the Upper Body Tube	<u>37</u>
4.1.4 Assemble the Weather Protection Body	<u>38</u>
4.1.5 Mount the Top Section	<u>39</u>
4.1.6 WP30 Disassembling the Top Section	<u>40</u>
4.1.7 Handle Wind Screen with Care	<u>42</u>
5 WP40 / WP30 Calibration	
6 Accessories	
6.1 WP40-90 Weather Protection	<u>45</u>
6.2 WP62 Weather Protection for M4261 (Legacy) and M4262	<u>46</u>
6.3 Pole Mount Adapter	<u>47</u>
6.4 WP40-90 / WP62 Windscreen Replacement	<u>48</u>

6.5 WP30-90 / WP61 Windscreen Replacement	<u>48</u>
6.6 WP30-150 Windscreen Replacement	<u>49</u>
6.7 ½" Windscreen 90 mm	<u>49</u>
6.8 Class 1 Sound Calibrator 94 dB	<u>50</u>
6.9 Class 2 Sound Calibrator	<u>50</u>
6.10 Manufacturer Calibration Certificate	<u>51</u>
6.11 Lightweight Tripod	<u>52</u>
6.12 ASD and WP-ASD Cables	<u>53</u>

7 Further Information

7.1 My NTi Audio	<u>55</u>
7.2 Important note for NTi Audio Microphones	<u>56</u>
7.3 Calibration Certificate	<u>56</u>
7.4 Service and Repairs	<u>57</u>
7.5 Capsule Replacement Instructions	<u>57</u>
7.6 Warranty Conditions	<u>60</u>
7.6.1 International warranty	<u>60</u>
7.6.2 Limitations	<u>60</u>
7.6.3 Statutory Rights	<u>60</u>
7.7 CE Declaration of Conformity	<u>61</u>
7.8 Information for Disposal and Recycling	<u>62</u>
7.8.1 Regulations for the EU and other European countries with corresponding laws	<u>62</u>

7.8.2 Other countries outside the EU	<u>62</u>
8 Technical Data Measurement Microphones	
8.1 Certified Class 1 Measuring Microphones	<u>63</u>
8.2 Measuring Microphones	<u>66</u>
8.3 Technical Data Microphone Preamplifiers	<u>72</u>
8.4 Outdoor Measurement Microphones	<u>74</u>
8.4.1 WP40 Specifications / WP62 Specifications	<u>74</u>
8.4.2 WP30 / WP61 Specifications (Legacy)	<u>77</u>
8.4.3 Influence of Wind	<u>78</u>
8.4.3.1 Windscreen 90 mm	<u>78</u>
8.4.4 WP40/WP62 90mm Windscreen	<u>81</u>
8.5 Typical Frequency Response of Measurement Microphones	<u>84</u>
8.6 Free Field - Pressure Correction Factors	<u>87</u>
8.7 Free-field and Diffuse-field Sensitivity of M2230 and M2340	<u>91</u>
8.8 Spectral Correction for horizontal and vertical Sound Incidents using the Outdoor Microphone	<u>92</u>
9 Safety instructions	

1 Overview

1.1 Measurement Microphones

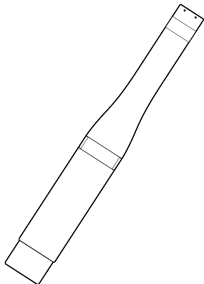
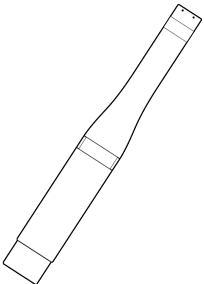
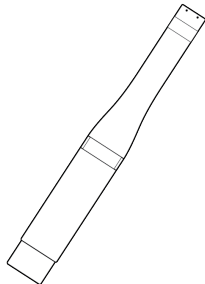
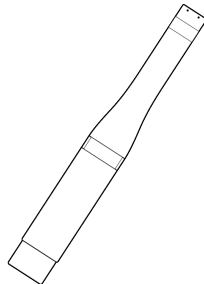
M2211	M2215	M2230	M2340
			
<p>General purpose measurement microphone class 1 frequency response, metal diaphragm</p>	<p>Measurement microphone for high sound levels (up to 153 dB), class 1 frequency response, metal diaphragm</p>	<p>Certified Class 1 measurement microphone in accordance with IEC 61672, metal diaphragm</p>	<p>Class 1 measurement microphone in accordance with IEC 61672, metal diaphragm, system self-test (CIC) with XL2 or XL3</p>
<p>consists of MA220 PreAmplifier and 7052 capsule</p>	<p>consists of MA220 PreAmplifier and 7056 capsule</p>	<p>consists of MA220 PreAmplifier and MC230 or MC230A capsule</p>	<p>consists of MA230 PreAmplifier and MC230A capsule</p>

1 Overview

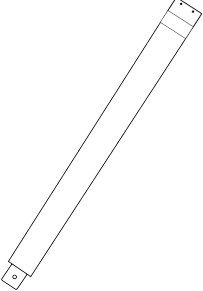
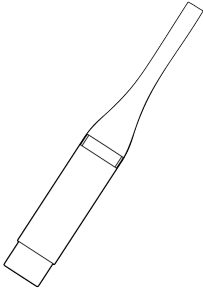
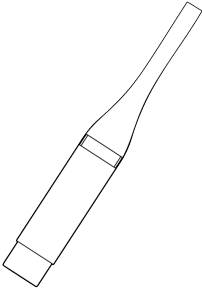
M2914	M4261 (Legacy)	M4262
 A line drawing of a long, thin, cylindrical microphone with a small circular element at the bottom tip.	 A line drawing of a microphone with a wider, flared body and a small circular element at the bottom tip.	 A line drawing of a microphone with a wider, flared body and a small circular element at the bottom tip, similar to the M4261 model.
High-performance microphone for acoustic measurements of very low sound pressure levels	Cost-effective class 2 measurement microphone for general sound level testing and service of audio-acoustic installations	Cost-effective class 2 measurement microphone for general sound level testing and service of audio-acoustic installations
requires ICP Adapter ASD	with permanently-installed capsule	with permanently-installed capsule

1.2 Outdoor Measurement Microphones

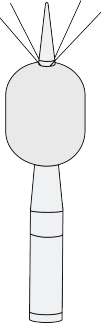
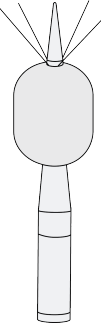
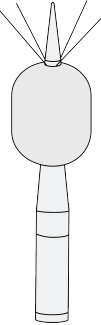
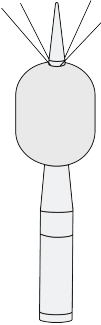
M2230-WP	M2340-WP	M4261-WP (Legacy)	M4262-WP
			
<p>Certified outdoor measurement microphone, class 1 in accordance with IEC 61672</p>	<p>Certified outdoor measurement microphone, class 1 in accordance with IEC 61672, system self-test (CIC) with XL2 or XL3</p>	<p>Outdoor measurement microphone, class 2 (not certified).</p>	<p>Outdoor measurement microphone, class 2 (not certified).</p>
<p>consists of M2230 Measurement Microphone + WP40 Weather Protection (or WP30 Legacy) with 90 mm windscreen</p>	<p>consists of M2340 Measurement Microphone + WP40 Weather Protection (or WP30 Legacy) with 90 mm windscreen</p>	<p>consists of M4261 Measurement Microphone (Legacy) + WP62 Weather Protection with 90 mm windscreen</p>	<p>consists of M4262 Measurement Microphone + WP62 Weather Protection with 90 mm windscreen</p>

1.3 Microphone Preamplifiers

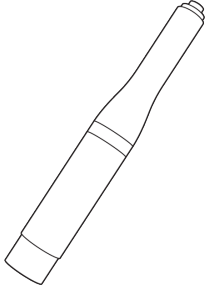
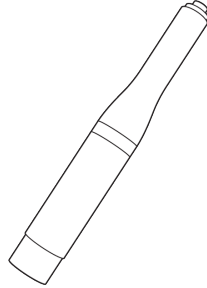
MA220	MA230
	
Microphone preamplifier compatible with 1/2" pre-polarized capsules	Microphone preamplifier compatible with 1/2" pre-polarized capsules, system self-test (CIC) with XL2 or XL3

1.4 Scope of Delivery

M2211	<ul style="list-style-type: none">• Measurement Microphone consisting of<ul style="list-style-type: none">• Microphone PreAmplifier MA220• Microphone Capsule 7052• Dust cap• 33 mm Windscreen• Microphone-holder with Adapter 5/8" – 3/8"• Operating Manual
M2215	<ul style="list-style-type: none">• Measurement Microphone consisting of<ul style="list-style-type: none">• Microphone PreAmplifier MA220• Microphone Capsule 7056• Dust cap• 33 mm Windscreen• Microphone-holder with Adapter 5/8" – 3/8"• Operating Manual

M2230	<ul style="list-style-type: none">• Measurement Microphone consisting of<ul style="list-style-type: none">• Microphone PreAmplifier MA220• Microphone Capsule MC230 or MC230A• Dust cap• 50 mm Windscreen• Microphone-holder MH01 with Adapter 5/8" – 3/8"• Operating Manual• Individual Frequency Response Chart
M2340	<ul style="list-style-type: none">• Measurement Microphone consisting of<ul style="list-style-type: none">• Microphone PreAmplifier MA230• Microphone Capsule MC230A• Dust cap• 90 mm Windscreen• Microphone-holder with Adapter 5/8" – 3/8"• Operating Manual• Individual Frequency Response Chart

M4261 (Legacy)	<ul style="list-style-type: none">• Measurement Microphone• 33 mm Windscreen• Microphone-holder with Adapter 5/8" – 3/8"• Operating Manual
M4262	<ul style="list-style-type: none">• Measurement Microphone• 33 mm Windscreen• Microphone-holder with Adapter 5/8" – 3/8"• Operating Manual

1 Overview

WP40-90	<ul style="list-style-type: none">• Bird spike BS03• 90 mm Windscreen• Protection cage• Upper body tube with Allen key mount• Lower body tube• Footer plate with tripod mounting thread (incl. 3 Allen screws)• Allen key
WP62	<ul style="list-style-type: none">• Bird spike BS03• 90 mm Windscreen• Protection cage• Upper body tube with Allen key mount• Lower body tube• Footer plate with tripod mounting thread (incl. 3 Allen screws)• Allen key

2 Description

The plug-on measurement microphones combined with the XL2 or XL3 Analyzer form a comprehensive sound level meter and acoustic analyzer.

2.1 Integrated PreAmplifier

The microphone bodies contain a PreAmplifier and require 48 VDC Phantom power supply for operation. They combine high dynamic range and wide frequency range with low noise. The measurement microphones can also be connected with an ASD Cable to the XL2 or XL3 Analyzer for measurements at remote locations or for reduction of acoustic reflections.

2.2 Electronic Data Sheet

The microphones include an electronic data sheet. The Automated Sensor Detection (ASD) of the XL2 or XL3 Analyzer automatically reads this data, i.e. the microphone model and calibration data. This promotes faster setup and ensures accurate measurements.

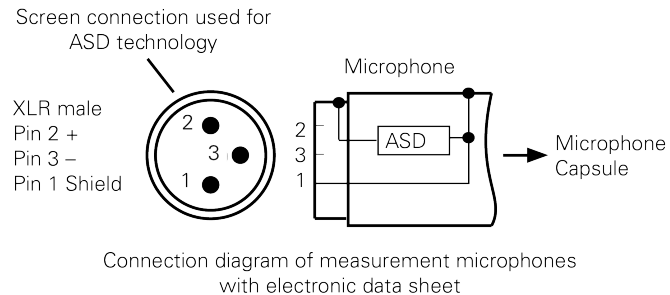

2.3 Connecting to XL2 or XL3

2.3.1 Microphone plugs directly into the XL2 or XL3

The XL2 and XL3 automatically read the electronic data sheet of the connected microphone as follows:

- Connect the measurement microphone to the XL2/XL3.
- Switch on the XL2/XL3.



The XL2 and XL3 read the electronic data sheet of the connected microphone during a brief initialization process prior to the first measurement.

2.3.2 Microphone Connection via the ASD Cable

The NTi Audio measurement microphones can be connected with an ASD Cable to the XL2 or XL3 Analyzer for measurements at remote locations or for reducing acoustic reflections. The electronic data sheet is transmitted via the XLR connector's housing. Do not touch this during the brief initialization period to ensure the complete data sheet is recognized by the XL2 or XL3. The automated sensor detection does not disturb any measurements. You may join 5- or 10-meter ASD Cables together in series. The ASD technology supports accurate data communication up to a combined cable length of 20 meters (= 65 feet), which is also the maximum cable length for CIC operation.

2.3.3 Microphone Connection via a professional Audio Cable

For distances longer than 20 meter (= 65 feet) use a high quality, low capacitance standard professional audio cable (NOTE: CIC operation not possible with this configuration!).

The microphone sensitivity has to be entered manually into the XL2 or XL3 Analyzer – Or, alternatively, connect the microphone first directly to the XL2 or XL3, whereby the analyzer reads the sensitivity and remembers this value. Afterwards, connect the audio cable between the analyzer and the microphone.

3 WP40 Outdoor Measurement Microphones

The Outdoor Measurement Microphones offer a weather-protected measurement solution for the M-Series Microphones allowing acquisition of environmental noise data in outdoor applications. The corrosion free polymer housing, windscreen with built-in water guard, water-repellent membrane and bird spike provide excellent protection from rain, wind, dust and perching birds.

Outdoor Measurement Microphone Types:

- M2230-WP:
M2230 + WP40 Weather Protection + WP ASD Cable;
- M2340-WP:
M2340 + WP40 Weather Protection + WP ASD Cable.

1 year maintenance:

WP40-90 / WP62-90

Windscreen replacement kit

90 mm Windscreen with built in
water protection grid.

600 040 142

2 years maintenance:

WP40-90 / WP62-90

Full Service kit

Cage with water repellent membrane
and Windscreen with built in water pro-
tection grid.

WP40-90 # 600 040 141

WP62-90 # 600 040 151

WP ASD Cable 5 m: # 600 000 306

WP ASD Cable 10 m: # 600 000 307

WP ASD Cable 20 m: # 600 000 308

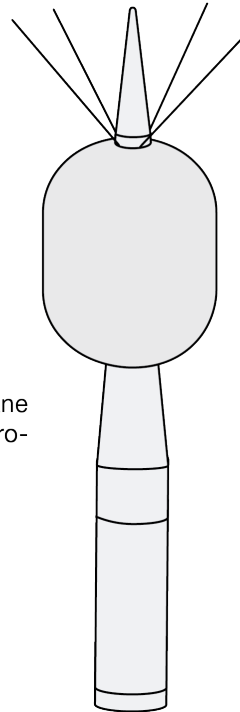



- Do not install the Outdoor Measurement Microphones in horizontal direction. Raindrops may damage the measurement microphone.
- The snap mechanism works only at temperatures above -15°C / 5°F (as the O-Ring stiffens). In colder conditions we suggest you warm up the housing first, e.g. with your hands.

3.1 Outdoor Measurement Microphones Class 1 / Type 1 certified

The Outdoor Measurement Microphones M2230-WP and M2340-WP fulfill the Class 1 requirements according to IEC 61672 and ANSI S1.4. For compliance with horizontal (community) and vertical (air-plane) sound incidence a spectral correction is employed in the associated M-Series Microphones.



Always activate the applicable frequency correction filter in the XL3. The filter ensures that the measurements accuracy meets the class 1 requirements of IEC 61672 and ANSI S1.4.

3.2 WP40 Assembling

This section describes how to install the Measurement Microphone into the Weather Protection kit.

3.2.1 Install WP-ASD Cable

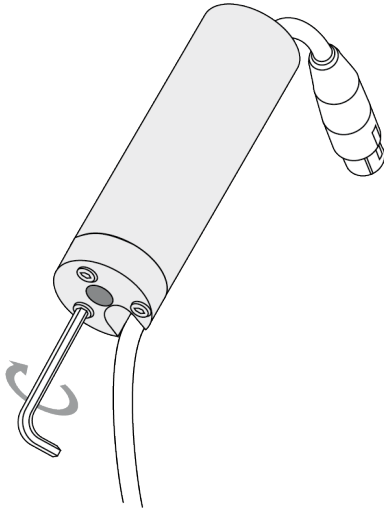

- Feed the female XLR of the ASD Cable through the bottom of the lower body tube;
- Attach the footer plate to the lower body tube using the three Allen screws, feeding the cable through the side slot of the footer plate.

Mounting:



- **Torque:** Tighten the three M3×20 mm screws to a torque of 0.9–1.1 Nm.
- **Careful Installation:** These screws are threaded into plastic and must be tightened carefully. Do not overtighten. Ensure the two parts are pulled flush against each other and that each screw is fully inserted.
- **Thread-Locking:** The screws are equipped with a blue Tuflok® thread-locking patch, which increases resistance during installation to prevent loosening. This resistance is normal.

3.2.2 Insert Measurement Microphone

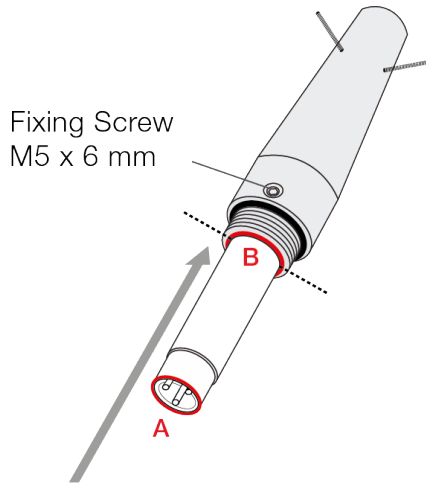

- Insert the microphone into the housing until the bottom end is flush with the housing i.e. position point A at point B. The end of the microphone should not be recessed in or stick out from the housing.
- Hint: Use a flat surface such as a table



The M5 × 6 screw must NOT be tightened without the microphone installed.

3.2.3 Attach the Microphone to the Upper Body Tube

- Tighten the fixing screw of the upper body tube. Do not over tighten the fixing screw.
- Again verify that the bottom end of the inserted microphone is in line with the bottom end of the upper body tube.
 - If you are using a M2211 or M2215, push the microphone further into the upper body by 3 mm. The top part of the capsule has to be 17 mm above the upper body housing of the Weather Protection.
- Attach the ASD Cable.

3 WP40 Outdoor Measurement Microphones

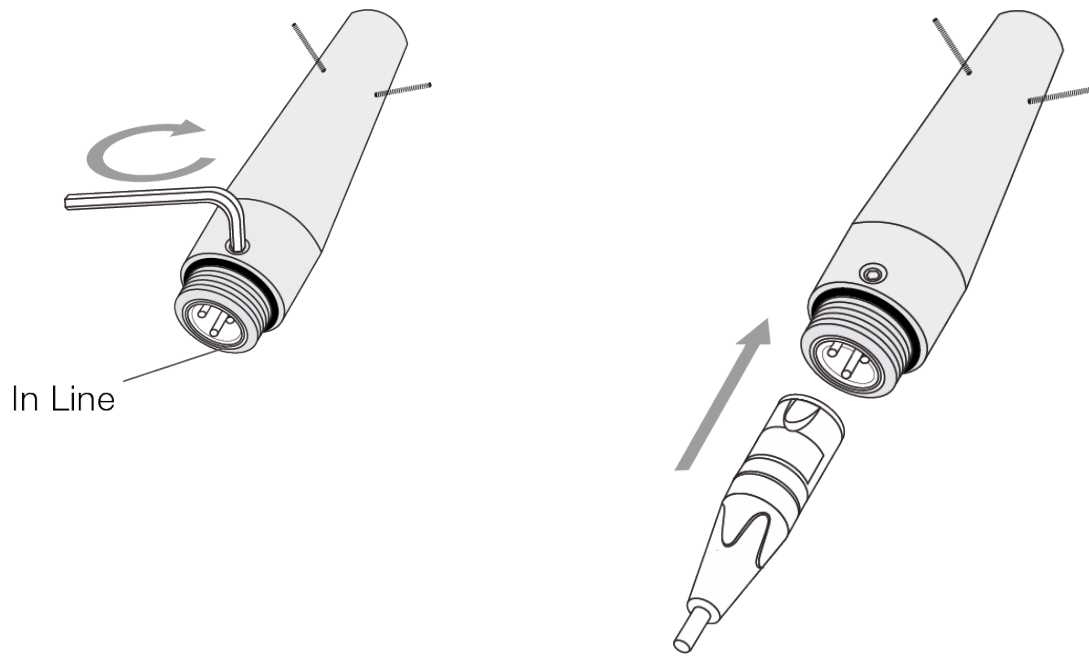

3.2.4 Assemble the Weather Protection Body

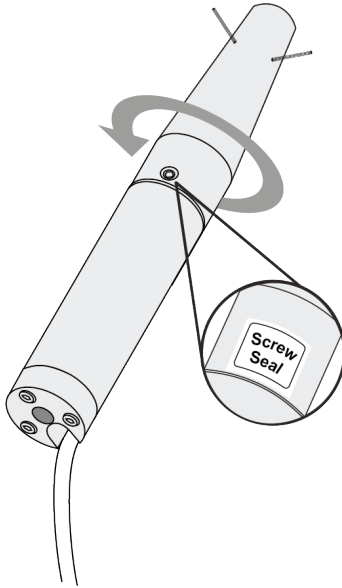

- Screw the upper part to the lower part of the weather protection housing and apply the seal sticker exactly over the screw to prevent water from penetrating.

3.2.5 Mount the Top Section

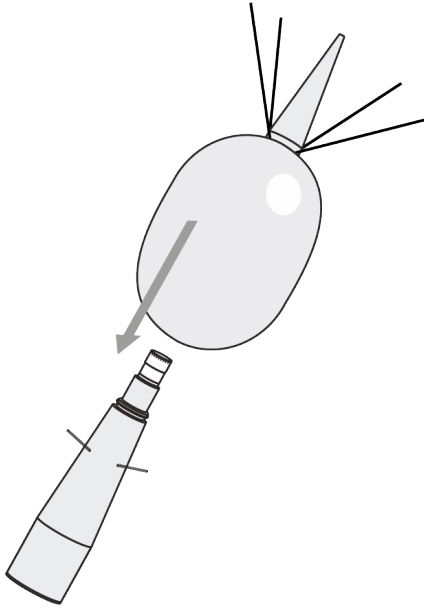

- The top section of the weather protection kit consists of the wind screen, the enclosed protection cage with water-repellent membrane and the bird spike. Gently slide the top section over the microphone tip and on to the upper body tube. You will feel a slight increase in resistance approximately 3 mm before the top section's final position. Slightly increase the pressure until the top section snaps into the final position with an audible click.

3.2.6 WP40 Disassembling the Top Section

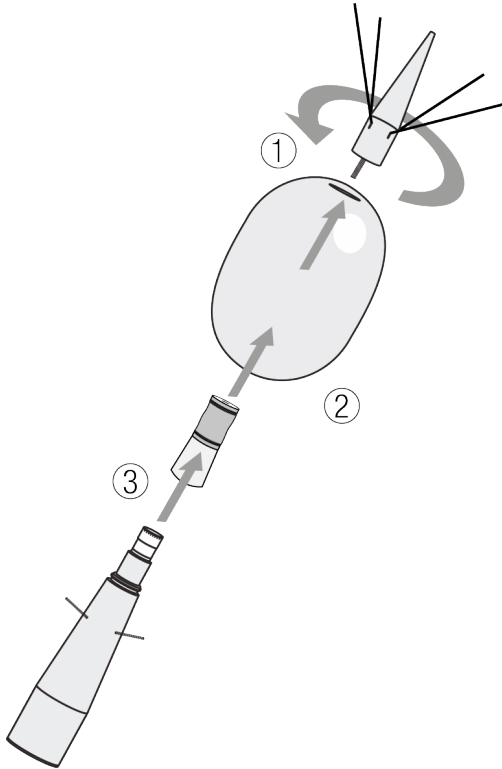

- Unscrew the bird spike and remove the windscreen from the microphone cage.
- Gently push up on the cage with two fingers. You will feel when the snap mechanism is released. Do not touch the water-repellent membrane!

3.2.7 WP40 with Dehumidifier

For the use of the outdoor measurement microphones (M2230-WP and M2340-WP) in weather-exposed locations with high humidity and temperatures that can cause dew, NTI recommends the TA202 dehumidifier. Due to the high impedance of the microphone capsule, even minimal moisture can affect its performance. The dehumidifier absorbs the moisture before it settles on the capsule, thereby providing accurate measurements, even under highly variable environmental conditions.

The TA202 dehumidifier is mounted between the MA220/MA230 preamplifier and the MC230A microphone capsule. It contains silica gel that effectively removes moisture from the air around the microphone capsule. As the gel absorbs moisture, it changes from its original blue color to a gray-pink hue. A window in the housing of the dehumidifier allows for monitoring the moisture content. For permanently installed, self-sufficient noise monitoring stations, NTI recommends routinely checking the color of the gel every three months.

By heating the TA202 dehumidifier to a maximum of +130°C for a few hours, it can be easily dried out and reused.

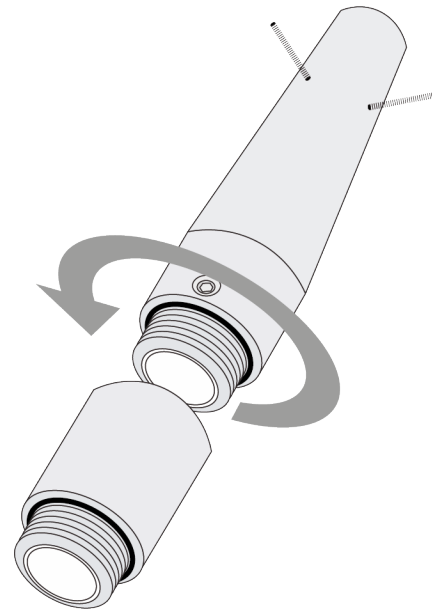
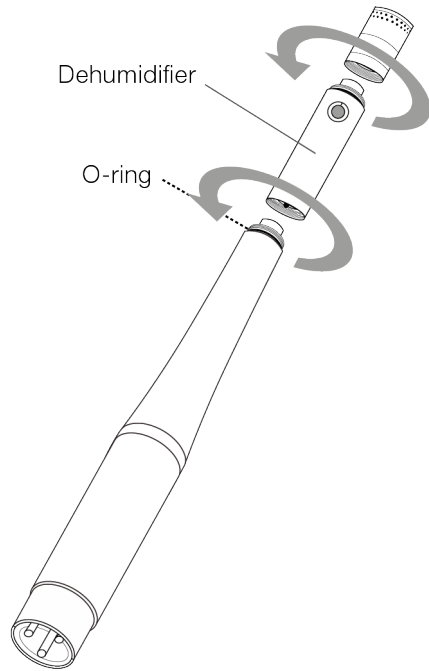

3 WP40 Outdoor Measurement Microphones

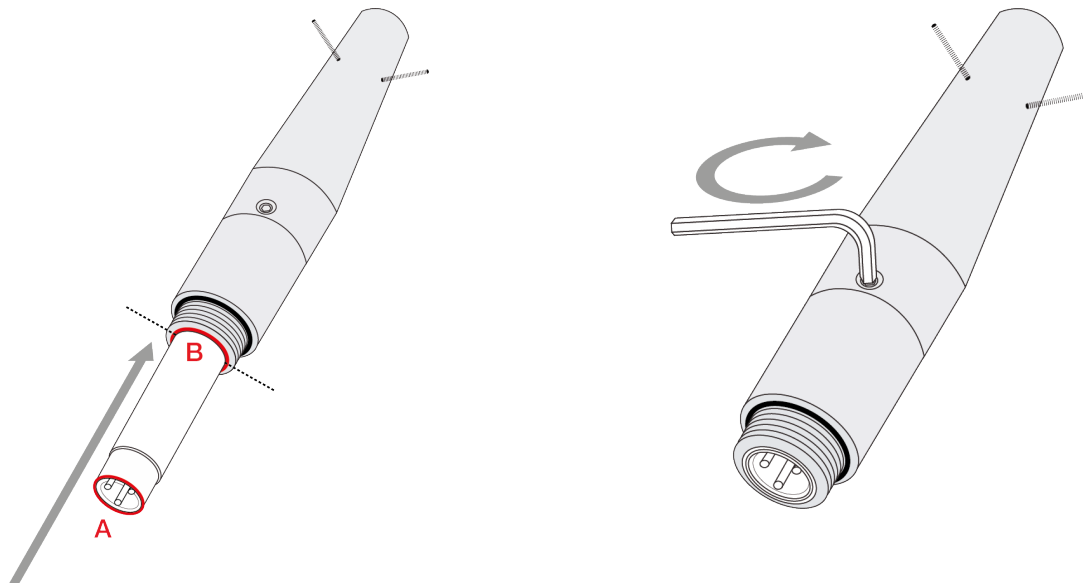

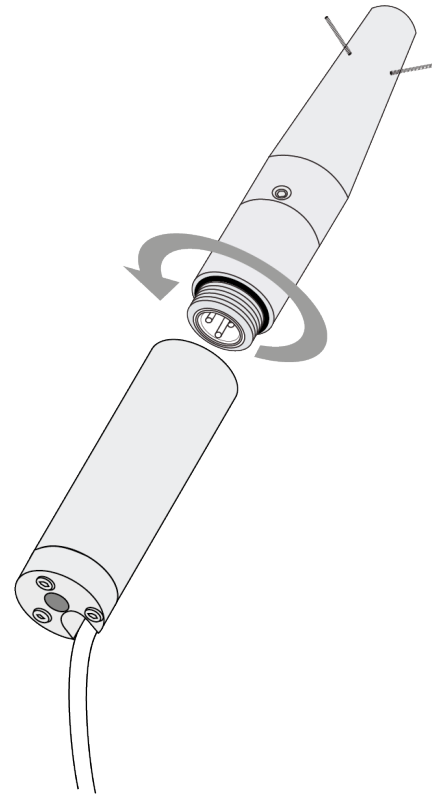
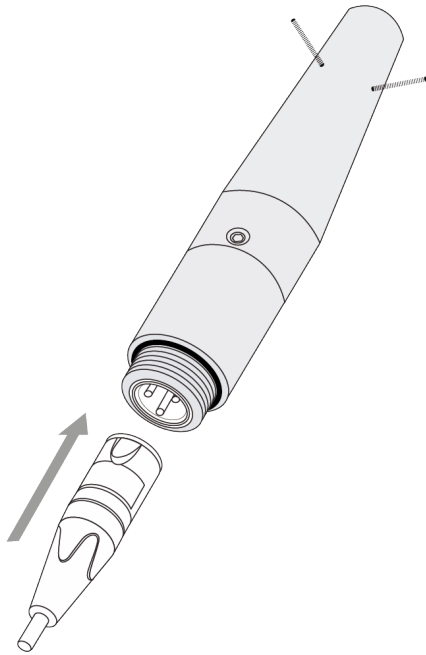

3.2.8 WP40 Maintenance

Yearly Maintenance

Due to temperature, sun, and rain, the windscreen of the WP40 is subjected to significant wear and tear. These environmental factors lead to continuous degradation of the material, compromising the windscreen's protective function over time. Extreme temperature fluctuations can cause the material to become brittle, while UV radiation from the sun can degrade the material and reduce its elasticity. Additionally, rain, especially acidic rain, can chemically attack the material and weaken its structure.

**1 year maintenance -
Windscreen replacement kit:**

**WP40-90 / WP62-90
Windscreen replacement kit**
90 mm Windscreen with built in
water protection grid.
600 040 142

Windscreen 90mm

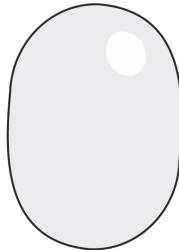

To prevent severe wear and associated loss of functionality of the windscreen, **NTi recommends replacing the windscreen of the WP40 annually.** This regular replacement ensures that the windscreen consistently performs optionally and reliably. This maintenance practice helps to preserve the device's performance and longevity.

WP40-90/WP62-90 Windscreen replacement kit 90 mm Windscreen with built in water protection grid. # 600 040 142

2-Year Maintenance

The acoustic protective membrane has a lifespan of only a few years when used outdoors. Due to the exposure to environmental elements such as rain and temperature fluctuations, the membrane gradually degrades overtime. This degradation can lead to a decline in its protective and acoustic performance. To ensure optimal functionality and protection, NTi recommends replacing the acoustic protective membrane every 2 years. This regular replacement schedule helps maintain the integrity of the membrane. By adhering to this 2-year replacement cycle, users can ensure the longevity and reliability of the WP40 in outdoor settings.

2 years maintenance - Full Service kit:

WP40-90 / WP62-90 Full Service kit

Cage with water repellent membrane and Windscreen with built in water protection grid.
WP40-90 # 600 040 141
WP62-90 # 600 040 151

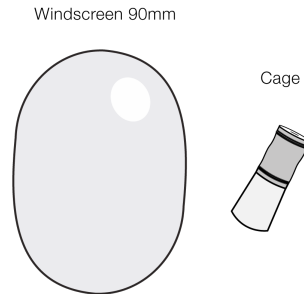

NTi Audio #:

- WP40-90 Full Service Kit: 600 040 141;
- WP62-90 Full Service Kit: 600 040 151.

3.2.9 Handle Wind Screen with Care

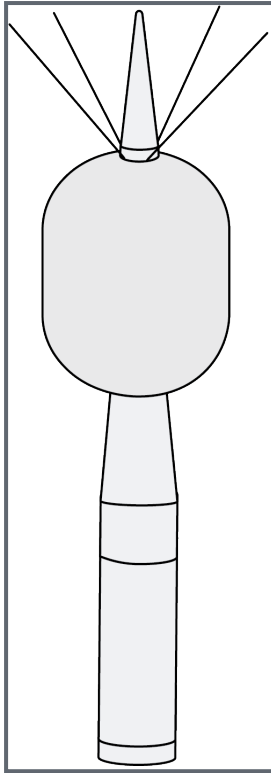

- The wind screen is fixed between the bird spike and the microphone cage.



- Do not squeeze the windshield due to the sensitive water protection grid contained within.
- Do not touch the waterrepellent membrane!

4 WP30 Outdoor Measurement Microphones (Legacy)

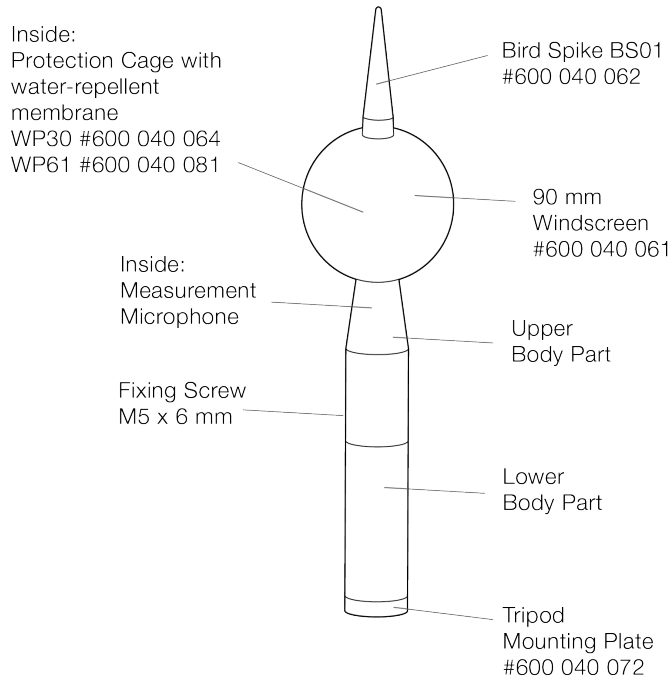

- Do not install the Outdoor Measurement Microphones in horizontal direction. Rain-drops may damage the measurement microphone.
- The snap mechanism works only at temperatures above -15°C / 5°F (as the O-Ring stiffens). In colder conditions we suggest you warm up the housing first, e.g. with your hands.

4.1 WP30 Assembling

This section describes how to install the Measurement Microphone into the Weather Protection kit.

4.1.1 Install ASD Cable

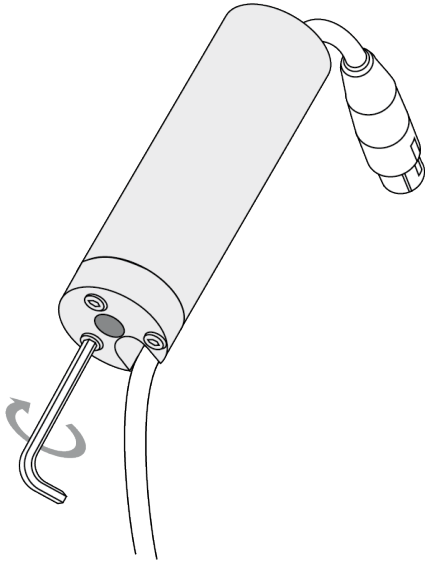

- Feed the female XLR of the ASD Cable through the bottom of the lower body tube;
- Attach the Tripod Mounting Plate to the lower body tube using the three Allen screws, feeding the cable through the side slot of the footer plate.

4.1.2 Insert Measurement Microphone

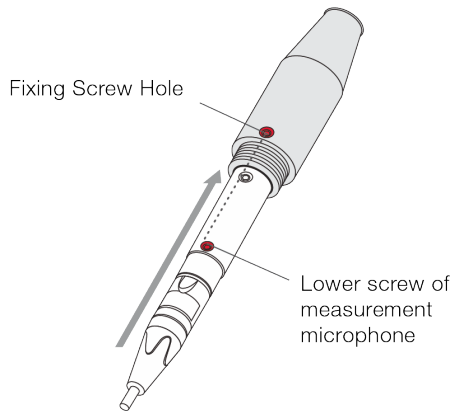

- Connect the measurement microphone to the female XLR of the ASD Cable.
- Insert the measurement microphone into the upper body tube so that the bottom end of the microphone is in line with the bottom end of the upper body tube. Align the fixing screw hole of the upper body tube with the lower screw of the measurement microphone (remove the fixing screw to see the lower screw head through the fixing screw hole).

4.1.3 Attach the Microphone to the Upper Body Tube

Attaching the fixing screw of the upper body tube onto the lower screw of the measurement microphone ensures that the microphone housing is not scratched.

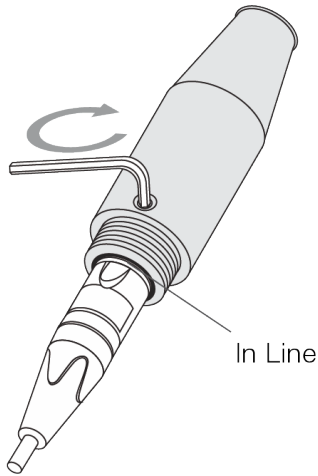

- Insert and gently tighten the fixing screw while jiggling the microphone. You will feel the fixing screw center in the head of the lower screw of the microphone. Do not over tighten the fixing screw.
- Again verify that the bottom end of the inserted microphone is in line with the bottom end of the upper body tube.

4.1.4 Assemble the Weather Protection Body

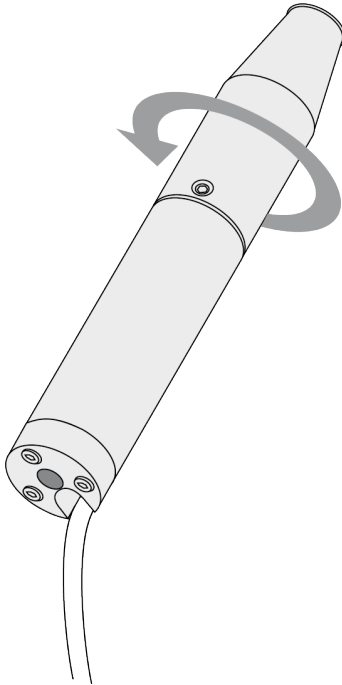

- Retract the ASD cable through the lower body tube and screw the lower body tube to the upper tube, ensuring that the cable does not twist during this operation.

4.1.5 Mount the Top Section

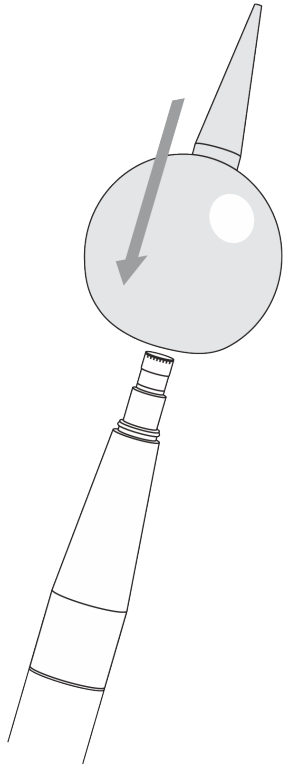

- The top section of the weather protection kit consists of the wind screen, the enclosed protection cage with water-repellent membrane and the bird spike. Gently slide the top section over the microphone tip and on to the upper body tube. You will feel a slight increase in resistance approximately 3 mm before the top section's final position. Slightly increase the pressure until the top section snaps into the final position with an audible click.

4.1.6 WP30 Disassembling the Top Section

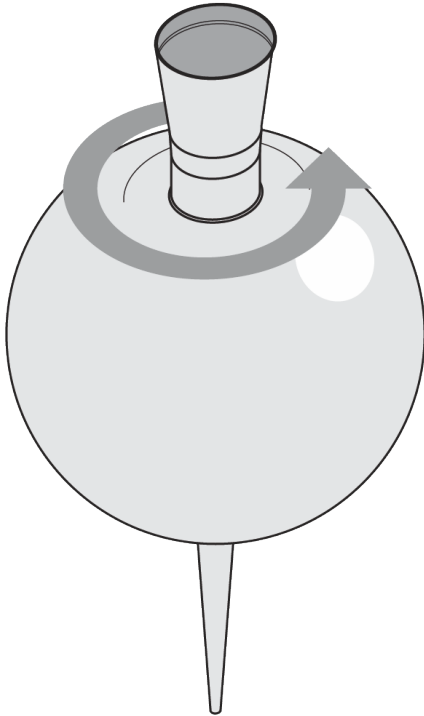

- The top section is snapped onto the body tube. Remove the top section by gently pulling the bird spike upwards. At the same time gently push up on the cage inside the wind screen with two fingers of your other hand. You will feel when the snap mechanism is released.
- Gently remove the top section and turn the top section upside down and hold it by the bird spike.
- Gently unscrew the cage from the hole of the wind screen. Do not touch the waterrepellent membrane!
- Assemble in reverse order.

4 WP30 Outdoor Measurement Microphones (Legacy)



- The outdoor windscreen is recommended to be replaced annually. The "WP30-90 / WP61 Windscreen Replacement" includes two 90 mm spare windscreens, NTi Audio # 600 040 061;
- The "WP30-150 Windscreen Replacement" includes two 150 mm spare windscreens, NTi Audio # 600 040 095.
- The water-repellent membrane in the top section is mounted with two O-rings. Inspect the O-rings (13 x 1 mm) and the membrane annually for proper seating and good condition. Do not touch the water-repellent membrane.

4.1.7 Handle Wind Screen with Care

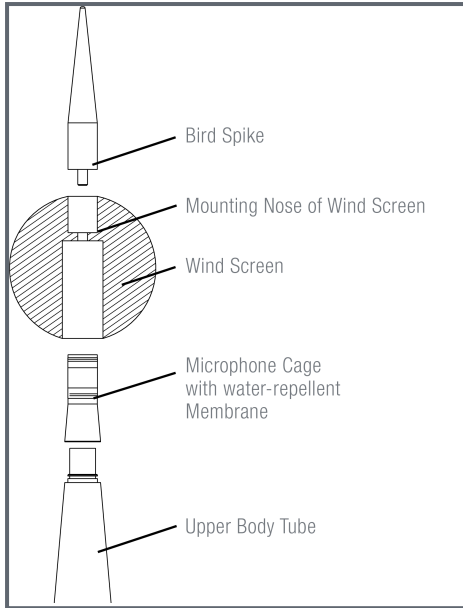

- The wind screen is fixed between the bird spike and the microphone cage.



- Do not apply any force onto the wind screen in order to prevent damage!
- Do not touch the waterrepellent membrane!

5 WP40 / WP30 Calibration

The design of the Outdoor Measurement Microphone supports easy calibration of the microphone. To calibrate, follow the procedure below:

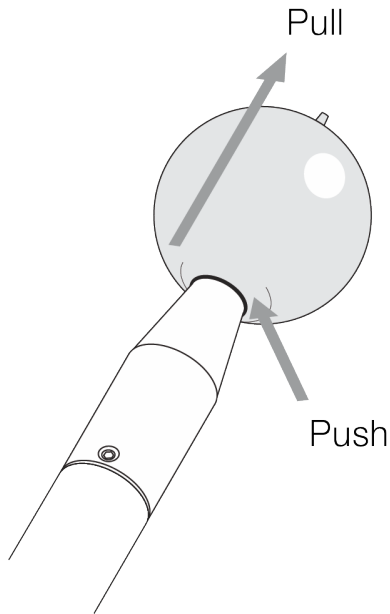

- The top section of the Outdoor Microphone is snapped on to the body tube. Remove the top section of the Outdoor Microphone by gently pulling the bird spike upwards. At the same time gently push up on the cage inside the wind screen with two fingers of your other hand. You will feel when the snap mechanism is released. Gently remove the top section;

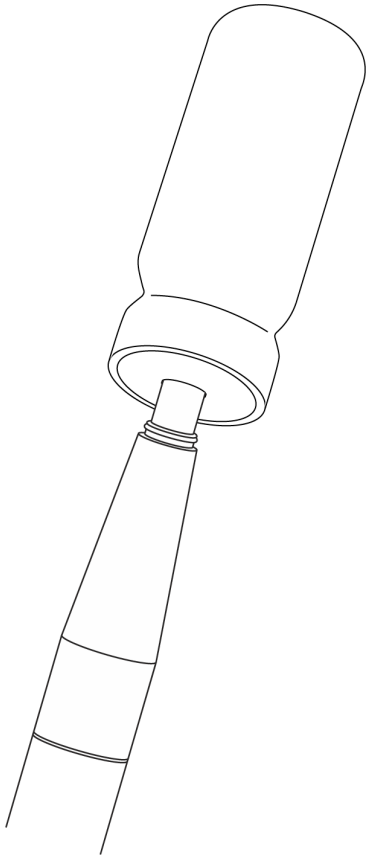

- Calibrate the microphone as described in the XL3 user manual using the NTi Audio Precision Calibrator;
- Snap the top section back into position on the body tube.

6 Accessories

6.1 WP40-90 Weather Protection

Protect your measurement microphones M2230 and M2340 from environmental impacts with this professional outdoor weather protection kit. Ideal for precise acquisition of environmental noise data in outdoor applications.

- Class 1 compliant with IEC 61672 and ANSI S1.4 for vertical and horizontal sound incidence
- Protection from rain and dust, wind and perching birds
- Built from corrosion-free materials
- Removable top section for easy microphone calibration
- Standard 3/8" tripod mount
- Weight: 202 g (7.13 oz.)
- Optional sturdy outdoor carrying case available
- Optional Pole Mount Adapter

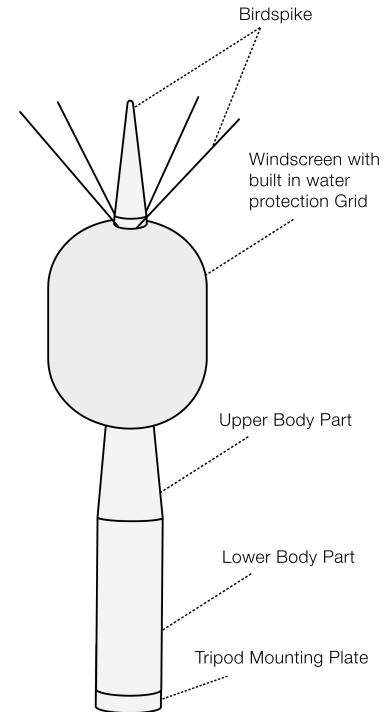

WP40-90: NTi Audio # 600 040 140

M2230-WP: M2230 Measurement Microphone (NTi Audio # 600 040 050) + WP40-90 Weather protection (NTi Audio # 600 040 140) + WP ASD Cable ¹

M2340-WP: M2340 Measurement Microphone (NTi Audio # 600 040 230) + WP40-90 Weather protection (NTi Audio # 600 040 140) + WP ASD Cable ¹

6.2 WP62 Weather Protection for M4261 (Legacy) and M4262

Protect your M4261 (Legacy) and M4262 microphone from environmental impacts with this professional outdoor weather protection kit.

- Class 2 compliant with IEC 61672 and ANSI S1.4 for vertical and horizontal sound incidence
- Protection from rain and dust, wind and perching birds
- Built from corrosion-free materials

¹WP ASD Cable 5 m NTi Audio # 600 000 306, WP ASD Cable 10 m NTi Audio # 600 000 307, WP ASD Cable 20 m NTi Audio # 600 000 308.

- Removable top section for easy microphone calibration
- Standard 3/8" tripod mount
- Weight: 270 g (9.5 oz.)
- Optional Pole Mount Adapter
- Optional sturdy outdoor carrying case available

NTi Audio # 600 040 080

6.3 Pole Mount Adapter

The outdoor measurement microphone may be installed on a pole using this adapter. The microphone is connected to the sound level meter by the ASD cable, which runs through the pole and the adapter to the microphone. The adapter is available in two different sizes.

- NTi Audio # 600 040 067, Pole Mount Adapter PM 1", supports pole diameter 25 – 33 mm (1 – 1.3")
- NTi Audio # 600 040 068, Pole Mount Adapter PM 1 ¼", supports pole diameter 32 – 44 mm (1.25 – 1.75")

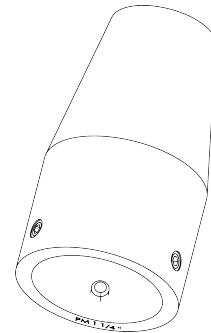

6.4 WP40-90 / WP62 Windscreen Replacement

The replacement package contains one 90 mm spare windscreens for outdoor measurement microphones. The outdoor windscreen is recommended to be replaced annually.

NTi Audio # 600 040 142

**1 year maintenance -
Windscreen replacement kit:**

**WP40-90 / WP62-90
Windscreen replacement kit**
90 mm Windscreen with built in
water protection grid.
600 040 142

Windscreen 90mm

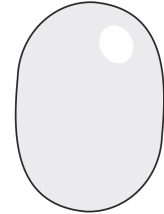

6.5 WP30-90 / WP61 Windscreen Replacement

The replacement package contains two 90 mm spare windscreens for outdoor measurement microphones. The outdoor windscreen is recommended to be replaced annually.

NTi Audio # 600 040 061

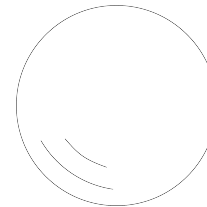

6.6 WP30-150 Windscreen Replacement

The replacement package contains one 150 mm spare windscreens for outdoor measurement microphones. The outdoor windscreen is recommended to be replaced annually.

NTi Audio # 600 040 095

6.7 ½" Windscreen 90 mm

for M2230, M2340, M2211 and M2215 measurement microphone

NTi Audio # 600 040 109

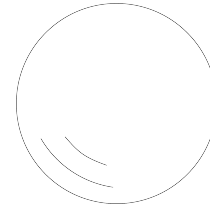
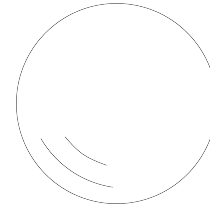

6.8 Class 1 Sound Calibrator 94 dB

The battery-operated Class 1 Sound Calibrator is classified for the calibration of class 1 measurement microphones, sound level meters and other acoustic measurement equipment. This precision microphone calibrator delivers 94 dB at a frequency of 1 kHz.

NTi Audio # 600 000 402

The optional $\frac{1}{4}$ " adapter for Class 1 Sound Calibrator 94 dB is required to fit $\frac{1}{4}$ " measurement microphones.

NTi Audio # 600 000 404

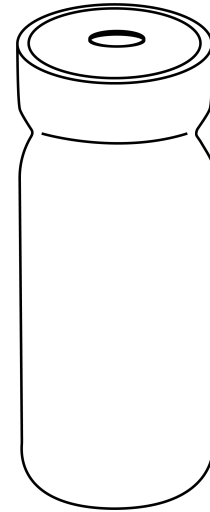

6.9 Class 2 Sound Calibrator

The battery-operated Class 2 Sound Calibrator is classified for the calibration of class 2 measurement microphones, sound level meters and other acoustic measurement equipment. This microphone calibrator delivers 114 dB at a frequency of 1 kHz.

NTi Audio # 600 000 394

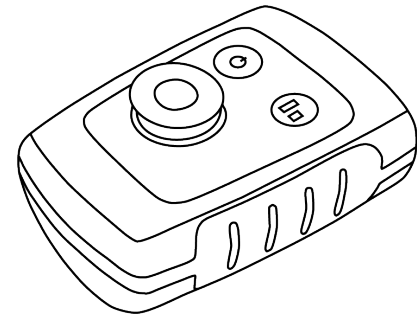

6.10 Manufacturer Calibration Certificate

The calibration certificate lists the individual product data with serial number. The calibration and adjustment procedures follow the documentation and traceability requirements of the EN ISO / IEC 17025 standard. Annual re-calibration of the instrument is recommended ensuring accurate measurements.

NTi Audio # 600 000 018



6.11 Lightweight Tripod

Retractable, lightweight tripod with 1/4" ball head and 3/8" mounting thread. The flexible ball head mounts the XL2 or XL3 Analyzer at any angle. The tripod is suitable for all measurement microphones, outdoor measurement microphones and the TalkBox.

NTi Audio # 600 000 397

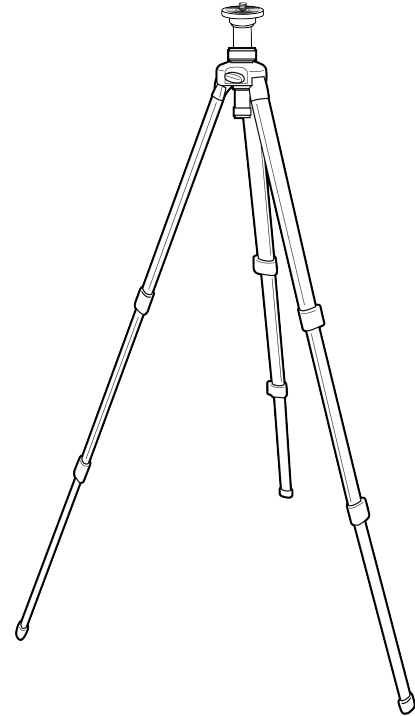

6.12 ASD and WP-ASD Cables

The ASD Cable allows for extended connections of the NTi Audio measurement microphones. It supports the transfer of the electronic data sheet from the microphone to the XL2 or XL3 Analyzer, as well as the CIC feature. The ASD technology for the electronic data sheet transfer is applicable for cable lengths up to 20 m (64 ft). Standard ASD Cables:

- 5 m (16 ft): NTi Audio # 600 000 336
- 10 m (32 ft): NTi Audio #600 000 364
- 20 m (64 ft): NTi Audio # 600 000 365

Waterproof WP-ASD Cables (with IP65 for use with WP40/WP62):

- 5 m (16 ft): NTi Audio # 600 000 306
- 10 m (32 ft): NTi Audio #600 000 307

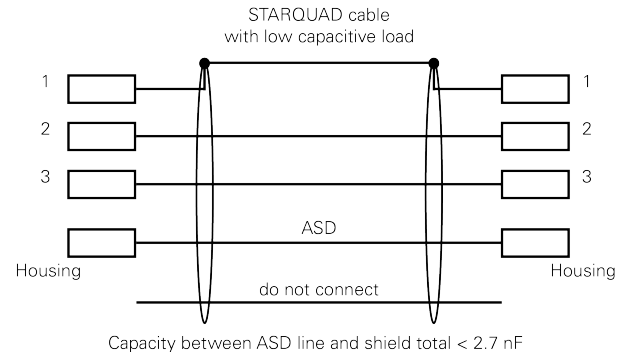
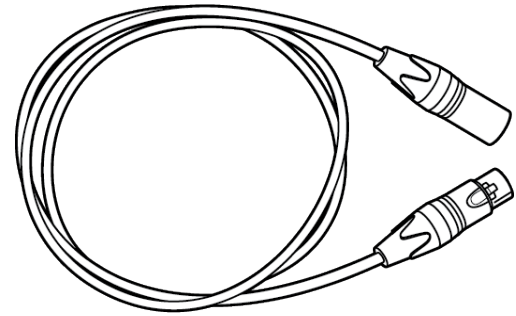

- 20 m (64 ft): NTi Audio # 600 000 308

7 Further Information

7.1 My NTi Audio

Register your instruments at My NTi Audio and benefit from the following possibilities:

- Free updates for your instruments
- Activation of optional product functions
- Premium access to downloads
- Receive application and product news
- Faster worldwide support
- Tracing support in case of loss or theft
- Calibration support

How to Register

- Open the web page “<https://my.nti-audio.com>”.
- You are prompted to login or create your My NTi Audio account.
- The web page “My NTi Audio Products” opens.
- Select the product type and enter the serial number.
- Confirm with “Register”.
- Now your product is listed in the table “My Products”.

7.2 Important note for NTi Audio Microphones

- Use the microphone for the intended purpose only.
- Protect the microphone from contamination by always using the supplied windscreen.
- Never use the microphone in a damp or wet environment.
- Do not jar or drop the microphone.
- Do not remove the microphone protective grid.
- Do not touch the microphone membrane.
- Remove the black dust cap of the 1/2" measurement microphones prior to use.
- In an outdoor environment, ensure that you install protection against lightning strikes.

7.3 Calibration Certificate

The NTi Audio measurement microphones have been carefully tested during production and corresponds to the specifications listed in "Technical Data". Calibration certificates for new products are optional.

NTi Audio recommends annual calibration of the products after the purchase. The calibration provides documented and traceable measurement accuracy and confirms that your NTi Audio product meets or exceeds the published specifications. The calibration and adjustment procedures follow the documentation and traceability requirements of the standard EN ISO / IEC 17025.

7 Further Information

For calibrations follow the service guidelines at <https://www.nti-audio.com/en/support/calibration-service>.

7.4 Service and Repairs

If your product is not functioning correctly or is damaged, please contact the local NTi Audio partner for assistance. If the product needs to be returned for service, kindly follow the service guidelines at <https://www.nti-audio.com/en/support/calibration-service>.

7.5 Capsule Replacement Instructions

The microphones for the XL2 and XL3 Analyzer include an electronic data sheet. The Automated Sensor Detection (ASD) of the XL2 and XL3 Analyzer automatically reads this data, i.e. the microphone model and calibration data. This promotes faster setup and ensures accurate measurements. In case of a capsule replacement, the electronic data sheet needs to be updated with the data of the new capsule.

Step-by-step instruction

- Install the new capsule on the microphone preamplifier.
- Plug the measurement microphone directly into the XL2.
- Install the latest firmware in the XL2, available at <https://my.nti-audio.com/support/xl2>.
- Start the XL2 Projector PRO Software. The computer requires online connection to the web.
- Connect the XL2 with the USB cable to the Projector PRO software, thus you see the XL2 display live on the computer monitor (if prompted select **COM-Port** on the XL2).
- Press the computer keyboard keys “Ctrl + Shift + F5” at the same time (alternatively “Ctrl + Alt + F5”)

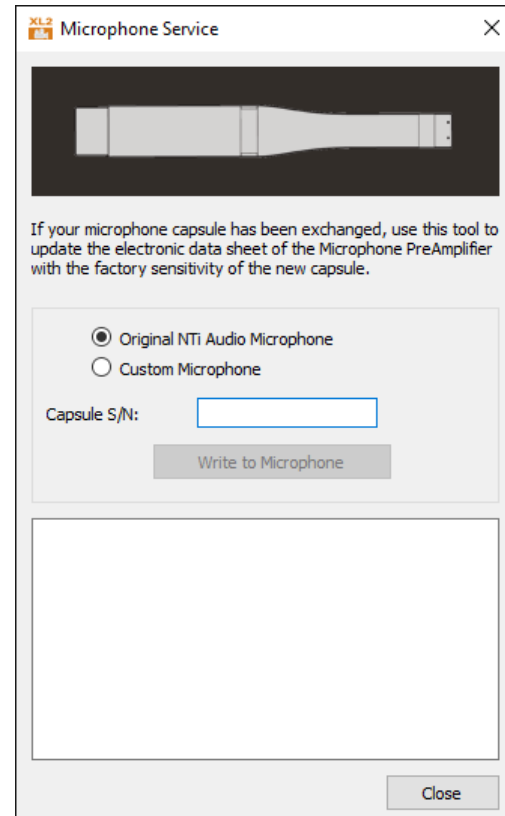

7 Further Information

- Select Original NTi Audio Microphone or Custom microphone.
- Case A): Original NTi Audio Microphone:
 - Enter the serial number of the new capsule;
 - Confirm by clicking **Write to MA220**;
 - Now XL2 reads the factory sensitivity of the new capsule from the NTi Audio server and stores the new data into the electronic data sheet of the preamplifier. You will be prompted if all is in good order.
- Case B): Custom microphone:
 - Enter the microphone sensitivity;
 - Confirm by clicking **Write to MA220**;
 - Now XL2 stores the microphone sensitivity as factory sensitivity in the electronic data sheet of the MA220 PreAmplifier;
 - Verify the setting in the “CALIBRATE” screen of the XL2 and perform a user calibration to verify if the new capsule works in good order.

7.6 Warranty Conditions

7.6.1 International warranty

NTi Audio guarantees the function of its products and the individual components for a period of three years from the date of sale. During this period, defective products will either be repaired free of charge or replaced.

7.6.2 Limitations

These guarantee provisions do not cover damage caused by accidents, transportation, incorrect use, carelessness, non-original accessories, the loss of parts, operation with non-specified input voltages, adapter types or incorrectly inserted batteries. NTi Audio accepts no responsibility for subsequent damage of any kind. The warranty will be voided by carrying out repairs or services by third parties who are not part of an approved NTi Audio Service Centre.

7.6.3 Statutory Rights

Consumers may have legal (statutory) rights under applicable national laws relating to the sale of consumer products. This warranty does not affect your statutory rights. You may assert any legal rights you have at your sole discretion.

7.7 CE Declaration of Conformity

We, the manufacturer NTi Audio AG, Im alten Riet 102, 9494 Schaan, Liechtenstein, do hereby declare that the measurement microphones M2230, M2340, M2211, M2215, M2914, M4261 (Legacy), M4262, the preamplifiers MA220, MA230 and accessories, comply with the following standards or other standard documents:

- EMC: 2014/30/EU
- Harmonized standards: EN 61326-1
- Directive 2011/65/EC on the restriction of the use of certain hazardous substances in electrical and electronic equipment (RoHS).
- Directive 2012/34/EU on waste electrical and electronic equipment (WEEE).

This declaration will become invalid if modifications to the instrument are carried out without the written approval of NTi Audio.

Date: 07. July 2023



Position: CEO



7.8 Information for Disposal and Recycling



Dispose of the instrument in accordance with the legal environmental regulations in the country.

7.8.1 Regulations for the EU and other European countries with corresponding laws

The instrument must not be disposed of in the household garbage. At the end of its service life, bring the instrument to a collecting point for electrical recycling in accordance with the local legal regulations.

7.8.2 Other countries outside the EU

Contact the respective authorities for the valid environmental regulations in the country.

8 Technical Data Measurement Microphones

8.1 Certified Class 1 Measuring Microphones

	M2340 Class 1 certified with self-examination	M2230 class 1 certified
Scope of delivery	MA230 preamplifier + MC230A microphone capsule	MA220 preamplifier + MC230A microphone capsule
Microphone type	Omnidirectional, condenser free-field microphone with continuous polarization	
Classification according to IEC 61672 and ANSI S1.4	Class 1 certified	
Microphone capsule	½" removable with thread 60UNS2 type WS2F according to IEC 61094-4	
Preamplifier type	MA230	MA220
Self-check	Yes	No

	M2340 Class 1 certified with self-examination	M2230 class 1 certified
Frequency response tolerance typical	± 1 dB @ 5 Hz – 20 Hz ± 1 dB @ >20 Hz – 4 kHz ± 1.5 dB @ >4 kHz – 10 kHz ± 2 dB @ >10 kHz – 16 kHz ± 3 dB @ >16 kHz – 20 kHz	
Individual frequency response	Freely available as Excel file: register the microphone on my.nti-audio.com and contact info@nti-audio.com	
Frequency range	5 Hz – 20 kHz	
Intrinsic noise typical	17 dB(A)	16 dB(A)
Maximum sound pressure level @ distortion factor 3%, 1 kHz	138 dB SPL	137 dB SPL
Sensitivity typical @ 1 kHz	27.5 dBV/Pa ± 2 dB (42 mV/Pa)	

8 Technical Data Measurement Microphones

	M2340 Class 1 certified with self-examination	M2230 class 1 certified
Temperature coefficient	< -0.015 dB / °C	
Temperature range	-10°C to +50°C (14°F to 122°F)	
Influence of air pressure	0.005 dB / kPa	
Influence of humidity (non-condensing)	< ±0.05 dB	
Humidity	5% to 90% RH, non-condensing	
Long-term stability	> 250 years / dB	
Power supply	48 VDC phantom power	
Power consumption	0.76 mA typical	2.3 mA typical
Electronic data sheet	NTi Audio ASD according to IEEE P1451.4 V1.0, Class 2, Template 27	
Output impedance	100 Ω symmetrical	
Output connector	balanced 3-pin XLR	
Diameter	20.5 mm (0.8")	

	M2340 Class 1 certified with self-examination	M2230 class 1 certified
Length	154 mm (6.1")	
Weight	100 g, 3.53 oz	
Protection class	IP51	
NTi Audio #	600 040 230	600 040 050

8.2 Measuring Microphones

	M2211 frequency response class 1	M2215 for high sound levels, frequency response class 1	M4261 class 2 (Legacy)	M4262 class 2
Includes	MA220 preamplifier + M2211 microphone capsule	MA220 preamplifier + M2215 microphone capsule	M4261 (Legacy) with fixed microphone capsule	M4262 with fixed microphone ECM capsule
Microphone type	Omnidirectional, condenser free-field microphone with continuous polarization		Electret capsule	

8 Technical Data Measurement Microphones

	M2211 frequency response class 1	M2215 for high sound levels, frequency response class 1	M4261 class 2 (Legacy)	M4262 class 2
Classification according to IEC 61672 and ANSI S1.4	Frequency response class 1		Class 2	
Microphone capsule	1/2" removable with thread 60UNS2 type WS2F according to IEC 61094-4		1/4" fixed mounted	
Preamplifier type	MA220		-	
Self-check	No			
Frequency response tolerance typical	± 1 dB @ 5 Hz – 20 Hz ± 1 dB @ >20 Hz – 4 kHz ± 1.5 dB @ >4 kHz – 10 kHz ± 2 dB @ >10 kHz – 16 kHz ± 3 dB @ >16 kHz – 20 kHz		$+1/-4.5$ dB @ 5 Hz – 20 Hz ± 1.5 dB @ >20 Hz – 4 kHz ± 3 dB @ >4 kHz – 10 kHz ± 45 dB @ >10 kHz – 16 kHz ± 5 dB @ >16 kHz – 20 kHz	$+1/-5$ dB @ 5 Hz – 20 Hz ± 1.5 dB @ 20 Hz - 4 kHz ± 3 dB @ 4 kHz – 20 kHz

	M2211 frequency response class 1	M2215 for high sound levels, frequency response class 1	M4261 class 2 (Legacy)	M4262 class 2
Individual frequency response freely available as Excel file	Freely available as Excel file: register the microphone on my.nti-audio.com and contact info@nti-audio.com			
Frequency range	5 Hz – 20 kHz			10 Hz – 30 kHz
Typical sensitivity @ 1 kHz	- 34 dBV/Pa ±3 dB (20 mV/Pa)	- 42 dBV/Pa ±3 dB (8 mV/Pa)	- 36 dBV/Pa ±3 dB (16 mV/Pa)	-36 dBV/Pa ±3 dB (16 mV/Pa)
Intrinsic noise typical	21 dB(A) SPL @ 20 mV/Pa	25 dB(A) SPL @ 8 mV/Pa	27 dB(A) SPL @ 16 mV/Pa	32 dB(A) SPL @ 16 mV/Pa
Maximum sound pressure level @ distortion factor 3%, 1 kHz	144 dB SPL	153 dB SPL	142 dB SPL	140 dB SPL
Temperature coefficient	< ±0.015 dB / °C		< ±0.02 dB / °C	< ±0.03 dB / °C
Temperature range	-10°C to +50°C (14°F to 122°F)		0°C to +40°C (32°F to 104°F)	

8 Technical Data Measurement Microphones

	M2211 frequency response class 1	M2215 for high sound levels, frequency response class 1	M4261 class 2 (Legacy)	M4262 class 2
Pressure coefficient	0.02 dB / kPa		-0.04 dB / kPa	
Influence of humidity (non-condensing)	< ±0.05 dB		< ±0.4 dB	
Humidity	5% to 90% RH, non-condensing			
Long-term stability	> 250 years / dB		-	
Power supply	48 VDC phantom power			
Power supply current	2.3 mA typical		1.7 mA typical	1.4 mA idle, 5 mA @ clip level
Electronic data sheet	NTi Audio ASD according to IEEE P1451.4 V1.0, Class 2, Template 27			
Output impedance	100 Ω symmetrical			
Output connector	balanced 3-pin XLR			

	M2211 frequency response class 1	M2215 for high sound levels, frequency response class 1	M4261 class 2 (Legacy)	M4262 class 2
Diameter	20.5 mm (0.8")			Housing: 20.5 mm (0.8"), Neck: 7.8 mm (0.3"), Recess for calibrator: 7 mm
Length	150 mm (5.9")			
Weight	100 g, 3.53 oz		83 g, 2.93 oz	83 g, 2.93 oz
Protection class	IP 51			
NTi Audio #	600 040 022	600 040 045	600 040 070	600 040 075

M2914 Low-Noise	
Microphone type	Omnidirectional, pre-polarized condenser, free field microphone
Capsule / transducer	1/2" detachable with 60UNS2 thread, type WS2F according IEC 61094-4 matched with preamplifier
Preamplifier type	MA214

M2914 Low-Noise	
Flatness tolerance bands typical	± 2 dB @ 10 Hz – 16 kHz ± 3 dB @ 5 Hz – 20 kHz
Typical sensitivity @ 1 kHz	320 mV/Pa
Residual noise floor typical	6.5 dB(A)
Maximum SPL @ THD 3%, 1 kHz, S_ typical	Peak 103 dB / RMS 100 dB
Temperature coefficient	$< \pm 0.01$ dB / °C
Temperature range	–20°C to +60°C (–4°F to 140°F)
Pressure coefficient	–0.00001 dB/Pa
Humidity	$< 90\%$ R.H., non-condensing
Power supply	ICP
Power supply current	4 – 20 mA typical

M2914 Low-Noise	
Output impedance	< 100 Ω
Connector	BNC
Diameter	12.7 mm (0.5"), protection grid 13.2 mm (0.52")
Length	135 mm (5.3")
Weight	250 g (8.8 oz)
Windscreen diameter	50 mm (2")
NTi Audio #	600 040 240

8.3 Technical Data Microphone Preamplifiers

	MA230	MA220
Microphone preamplifier	Compatible with 1/2" microphone capsules type WS2F according to IEC61094-4	
Typical Frequency range	1.3 Hz – 50.0 kHz	2.5 Hz – 50 kHz
Frequency Response flatness	± 0.2 dB, 10 Hz - 20 kHz	± 0.2 dB, 10 Hz - 20 kHz

8 Technical Data Measurement Microphones

	MA230	MA220
Phase linearity	$<\pm 5^\circ @ 20 \text{ Hz} - 20 \text{ kHz}$	$<\pm 10^\circ @ 20 \text{ Hz} - 20 \text{ kHz}$
Intrinsic noise typical	$2.4 \mu\text{V(A)} @ C_{in} 15 \text{ pF} \triangleq 9.1 \text{ dBA} @ 42 \text{ mV/Pa}$	$1.6 \mu\text{V(A)} @ C_{in} 18 \text{ pF} \triangleq 5.6 \text{ dBA} @ 42 \text{ mV/Pa}$
Maximum output voltage	$22 \text{ Vpp} \triangleq 7.78 \text{ Vrms} \triangleq 139.3 \text{ dB SPL} @ 42 \text{ mV/Pa}$	$21 \text{ Vpp} \triangleq 7.4 \text{ Vrms} \triangleq 138.9 \text{ dB SPL} @ 42 \text{ mV/Pa}$
Electronic data sheet	<ul style="list-style-type: none"> • Contains calibration data • Original NTi Audio sensitivity = 4.9 V/Pa • Save and read data with M-Series Microphones Analyzer • NTi Audio ASD according to IEEE P1451.4 V1.0, class 2, template 27 	
Self-check	Yes	No
Humidity	5% to 90% RH, non-condensing	
Power supply	48 VDC phantom power	
Power supply current	0.76 mA typical	2.3 mA typical
Electronic data sheet	NTi Audio ASD according to IEEE P1451.4 V1.0, class 2, template 27	
Output impedance	100 Ω symmetrical	
Output connector	balanced 3-pin XLR	

	MA230	MA220
Diameter	20.5 mm (0.8")	
Length	154 mm (6.1")	
Weight	100 g, 3.53 oz	
Protection class	IP51	
NTi Audio #	600 040 200	600 040 050

8.4 Outdoor Measurement Microphones

8.4.1 WP40 Specifications / WP62 Specifications

	M2230 + WP40-90	M2340 + WP40-90	M4261 (Legacy) + WP62-90	M4262 + WP62-90
Classification with XL2 or XL3 according to IEC 61672 and ANSI S1.4	Class 1	Class 1	Meets the Class 2 Frequency Response requirements	Meets the Class 2 Frequency Response requirements
Certifications	PTB	LNE, PTB, METAS	-	-

8 Technical Data Measurement Microphones

	M2230 + WP40-90	M2340 + WP40-90	M4261 (Legacy) + WP62-90	M4262 + WP62-90
Self-Check (CIC)	-	With XL2, with XL3 only with API	-	-
Environmental Protection	Rainfall with Wind Proofing under extreme conditions: Test A – PASSED – Duration 4 hours: <ul style="list-style-type: none"> • Rainfall intensity Rate/ Distribution: 1200 mm/h, Uniform water coverage from 45° to WP40 • Wind Speed / Direction: 30kmh (18.6 mph) / 90 ° to WP40 Test B – PASSED – Duration 40 minutes: <ul style="list-style-type: none"> • Rainfall intensity Rate/ Distribution: 1200 mm/h, Uniform water coverage from 45° to WP40 • Wind Speed / Direction: 110kmh (68.4 mph) / 90 ° to WP40 			
Mounting	Standard 3/8" tripod adapter included			
Windscreen Diameter	90 mm (3.54")			
Housing Diameter	36 mm (1.41")			

	M2230 + WP40-90	M2340 + WP40-90	M4261 (Legacy) + WP62-90	M4262 + WP62-90
Housing Length	366 mm (14.4")			
Weight (incl Micro- phone)	300g (10.6 oz)			
Protection class	IP64			
NTi Audio Article #	600 040 050 + 600 040 140	600 040 230 + 600 040 140	600 040 070 + 600 040 140	600 040 075 + 600 040 140
Optional Pole Mount Adapter	<ul style="list-style-type: none"> • Pole Mount Adapter PM 1" for Pole Diameter 25–33 mm (1–1.3") NTi Audio # 600 040 067 • Pole Mount Adapter PM 1 1/4" for Pole Diameter 32–44 mm (1.25–1.75") NTi Audio # 600 040 068 			

8.4.2 WP30 / WP61 Specifications (Legacy)

	M2230 + WP30-90	M2340 + WP30-90	M4261 (Legacy) + WP61
Classification with XL2 or XL3 according to IEC 61672 and ANSI S1.4	Class 1	Class 1	Meets the Class 2 Frequency Response requirements
Certifications	PTB	LNE, PTB	-
Self-Check (CIC)	-	With XL2, with XL3 only with API	-
Mounting	Standard 3/8" tripod adapter included		
Windscreen Diameter	90 mm (3.54")		
Housing Diameter	36 mm (1.41")		
Housing Length	363 mm (14.3")		
Weight (incl Microphone)	300g (10.6 oz)		
Protection class	IP54		

	M2230 + WP30-90	M2340 + WP30-90	M4261 (Legacy) + WP61
NTi Audio Article #	600 040 050 + 600 040 060	600 040 230 + 600 040 060	600 040 070 + 600 040 060
Optional Pole Mount Adapter	<ul style="list-style-type: none"> • Pole Mount Adapter PM 1" for Pole Diameter 25–33 mm (1–1.3") NTi Audio # 600 040 067 • Pole Mount Adapter PM 1 1/4" for Pole Diameter 32–44 mm (1.25–1.75") NTi Audio # 600 040 068 		

8.4.3 Influence of Wind

8.4.3.1 Windscreen 90 mm

The attenuation of wind noise provided by the 90 mm windscreen depends on wind speed. The absolute noise level measured with the 90 mm windscreen at wind speeds of up to 14 m/s is shown in the diagrams below:

8 Technical Data Measurement Microphones

- Absolute Noise Level with the XL3 + M2340/M2230 + 90mm Windscreen at different wind speeds with A-Weighting Filter active:

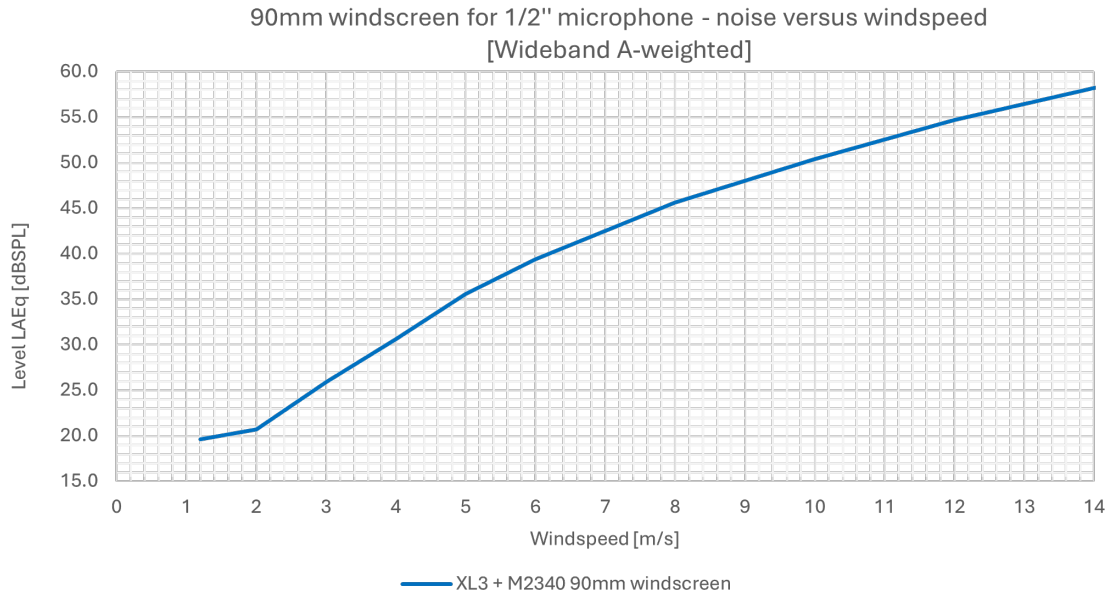

- Absolute Noise Level with the XL3 + M2340/M2230 + 90mm Windscreen for different frequencies at different wind speeds:

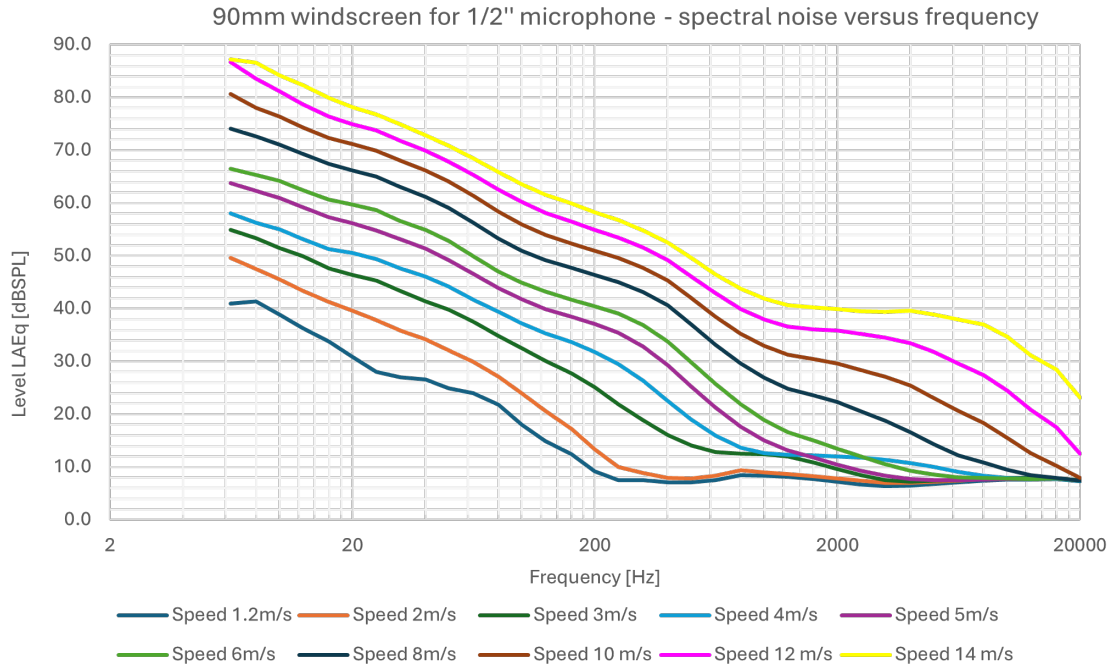

8.4.4 WP40/WP62 90mm Windscreen

The attenuation of wind noise provided by the WP40/WP62 90 mm Windscreen depends on wind speed. The absolute noise level measured with the WP40/WP62 90 mm Windscreen at wind speeds of up to 14 m/s are shown in the diagrams below:

- Absolute Noise Level with the WP40/WP62 - 90mm Windscreen at different wind speeds with A-Weighting Filter active:

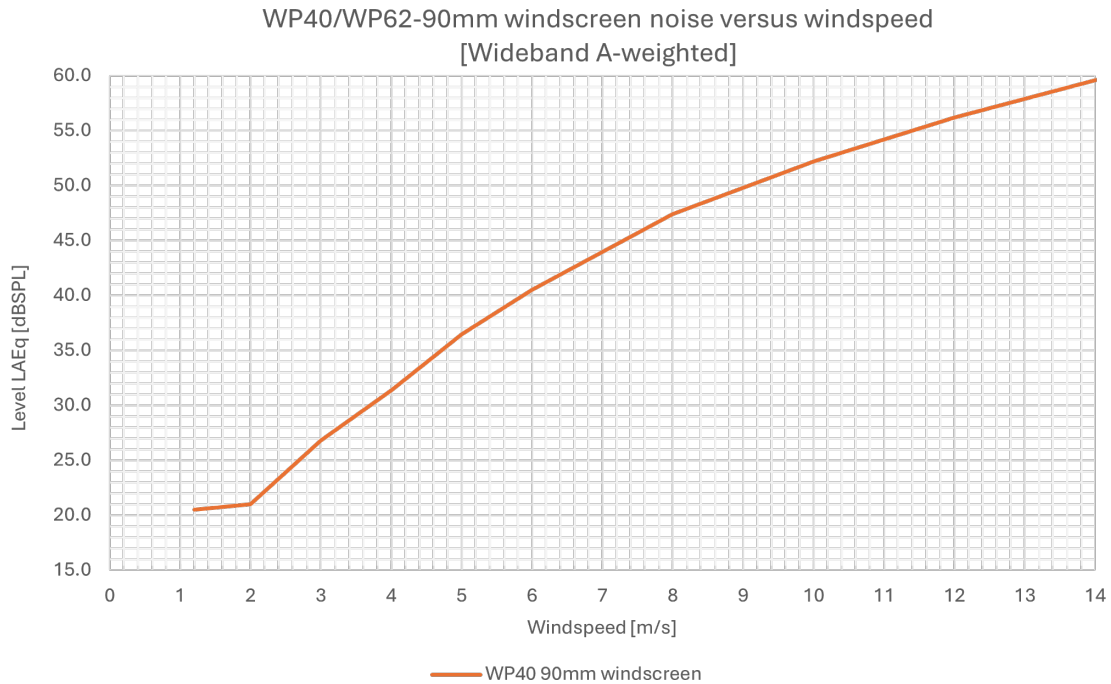

8 Technical Data Measurement Microphones

- Absolute Noise Level with the WP40/WP62 - 90mm Windscreen for different frequencies at different wind speeds:

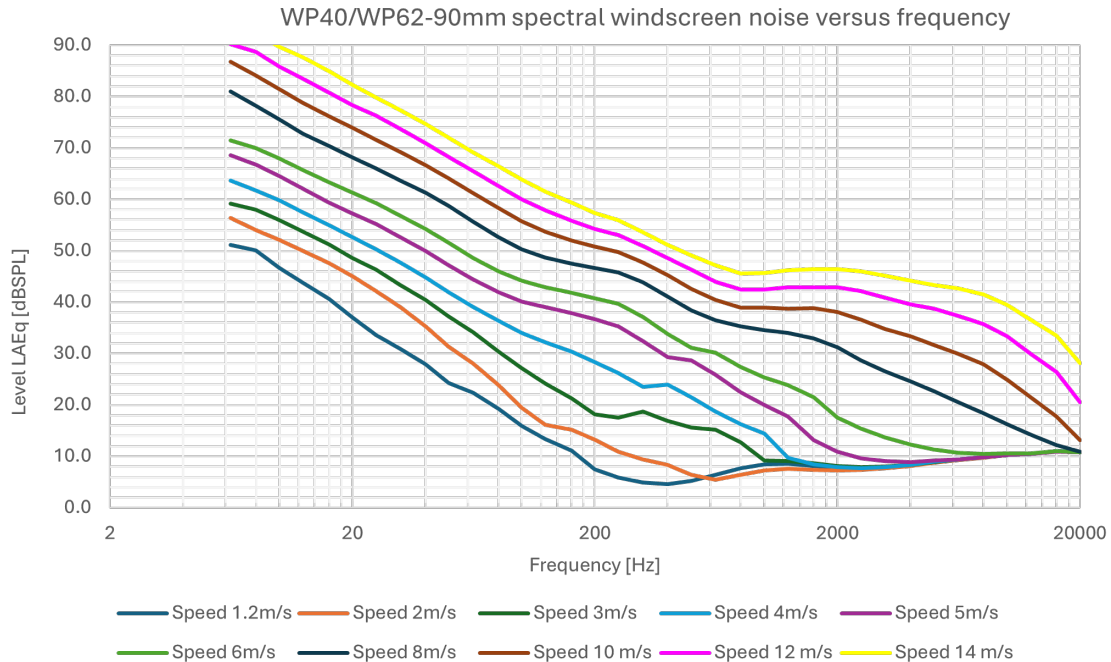

8.5 Typical Frequency Response of Measurement Microphones

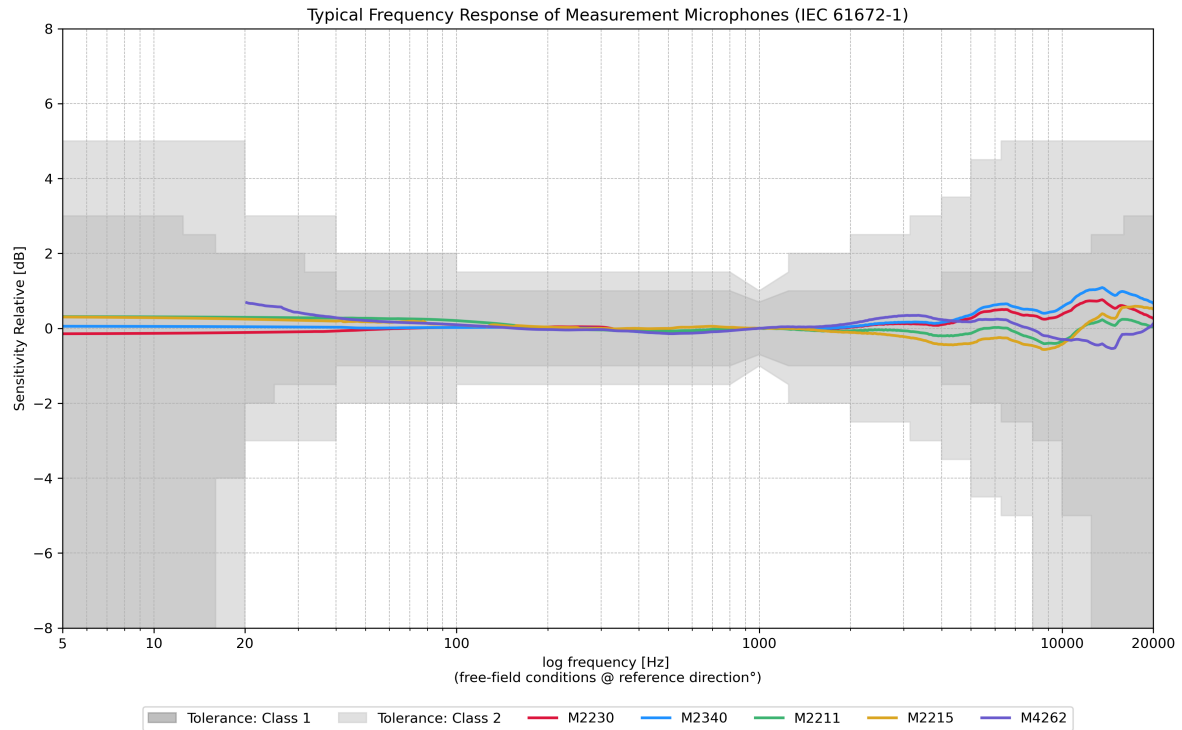

8 Technical Data Measurement Microphones



Our Class 2 microphones have a flat frequency response under standard conditions (1013.25 mbar, 23°C, 50% RH), just like our Class 1 microphones. However, their sensitivity may vary more with changes in these environmental conditions compared to the stricter limits of Class 1. Please keep this in mind when choosing the right microphone for your needs.

Here are NtAudio's recommendations for each application:

Class / Type	Microphone Model	Applications
Class 1 / Type 1 Certified	M2230 (1/2" detachable)	<ul style="list-style-type: none">• Noise Measurements• Building Acoustics• Legal Applications
	M2340 (1/2" detachable)	<ul style="list-style-type: none">• Noise Monitoring with system self-test (CIC)• Legal Applications

Class / Type	Microphone Model	Applications
Class 1 / Type 1	M2211 (1/2" detachable)	<ul style="list-style-type: none"> • Noise Measurements • Cinema Calibration • PA Rental
	M2215 (1/2" detachable)	<ul style="list-style-type: none"> • High-Level Noise Measurements
	M2914 (1/2")	<ul style="list-style-type: none"> • Low Noise Measurement
Class 2 / Type 2	M2010 (1/2" detachable)	<ul style="list-style-type: none"> • Industrial Manufacturing • Quality Control • R&D
	M2015 (1/2" detachable)	<ul style="list-style-type: none"> • Industrial Manufacturing • Quality Control • High-Level Measurements
	M4262 (1/4" fixed)	<ul style="list-style-type: none"> • Live Sound • Installations • Broadcast • Occupational Health

8.6 Free Field - Pressure Correction Factors

If a measurement microphone is located in a free-field environment, then the microphone capsule acts like a reflector at high frequencies, as the sound pressure increases in front of the membrane. M2211, M2215, M2230, M2340, M4261 (Legacy) and M4262 are free-field equalized measurement microphones, they compensate for the increased pressure internally. The calibration of the measurement microphones M2230 and M2340 with the B&K 4226 requires the accessory Adapter Ring MXR01, NTi Audio # 600 040 105. Please note, never touch the diaphragm of the measurement microphone capsule.

The calibrator no longer offers free-field conditions. Therefore, the free-field equalization of the microphone must be compensated. This needs to be considered prior to the calibration. The correction value needs to be added to the pressure response of the microphone.

Example:

- During the calibration, the XL2 or XL3 measures the sound level in the calibrator. If the B&K 4226 calibrator is used and is set to 16 kHz, then the XL2 or XL3 + M2230 reads just 86.7 dBA.
- The free-field sound level is calculated by summing the XL2 or XL3 measurement value and the correction value ($86.7 \text{ dB} + 7.3 \text{ dB} = 94.0 \text{ dB}$).

The following corrections apply with the B&K 4226 calibrator.

Nominal Frequency [Hz]	M2230, M2340 with MXR01 Adapter [dB]	M2211 [dB]	M2215 [dB]	Measurement Uncertainty U [dB]
31.5	-0.3	-0.2	0.0	0.3
63	0.0	0.0	0.0	0.3
125	-0.2	-0.1	-0.1	0.3
250	-0.2	-0.1	-0.1	0.3
500	-0.2	-0.1	-0.1	0.3
1000	0.0	0.0	0.0	0.3
2000	0.1	0.1	0.0	0.3
4000	0.7	0.7	0.4	0.3
8000	2.7	4.5	4.7	0.4
12500	7.2	5.8	6.1	0.7
16000	7.3	7.9	7.9	0.8

Correction values for other calibrators for M2230 and M2340.

Calibration	
Free-field correction	<ul style="list-style-type: none">• Class 1 sound calibrator 94 dB (NTi Audio #: 600 000 402): M2215 / M2211: -0.12 dB;• Class 1 sound calibrator 94 dB (NTi Audio #: 600 000 402) with 1/4" calibrator adapter NTi (Audio #: 600 000 404):<ul style="list-style-type: none">• M4260 (Legacy): +0.10 dB;• M4261 (Legacy): +0.20 dB;• M4262: +0.10 dB.

Calibration						
	M2230 / M2340 Configuration	Sound Calibrator				
		NTi CAL200	B&K 4231	Nor 1251	Nor 1256	Cirrus CR:515
Windscreen correction @ 1 kHz	No Accessory;					
	Windscreen 90mm ¹ ;					
	Windscreen 50mm ¹ ;	93.88 /	93.85 /	93.85 /	93.85 /	93.70 /
	WP40 Community ¹ (horizontal);	-0.12	-0.15	-0.15	-0.15	-0.30
	WP40 Aircraft ¹ (vertical).					
	WP30 vertical (Legacy)	93.69 /	93.66 /	93.66 /	93.66 /	93.51 /
		-0.31	-0.34	-0.34	-0.34	-0.49
	WP30 horizontal (Legacy)	93.69 /	93.66 /	93.66 /	93.66 /	93.51 /
		-0.31	-0.34	-0.34	-0.34	-0.49
Manufacturer calibration	<ul style="list-style-type: none"> • Recommended calibration interval: 1 year; • Calibration certificate for a new sound level meter is optionally available. 					

¹All required additional correction is handled by the instrument.

8.7 Free-field and Diffuse-field Sensitivity of M2230 and M2340

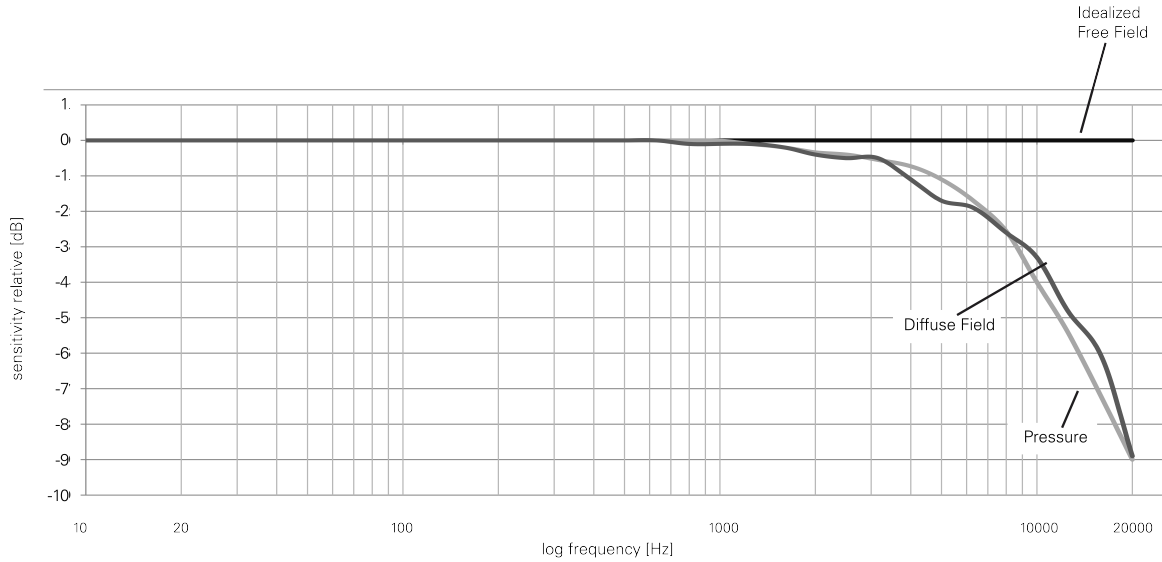

8.8 Spectral Correction for horizontal and vertical Sound Incidents using the Outdoor Microphone

The outdoor microphone M2230-WP fulfills Class 1 requirements of IEC 61672 and ANSI S1.4 for vertical sound incidence. For compliance with horizontal sound incidence a spectral correction is employed in the associated Sound Level Meter.

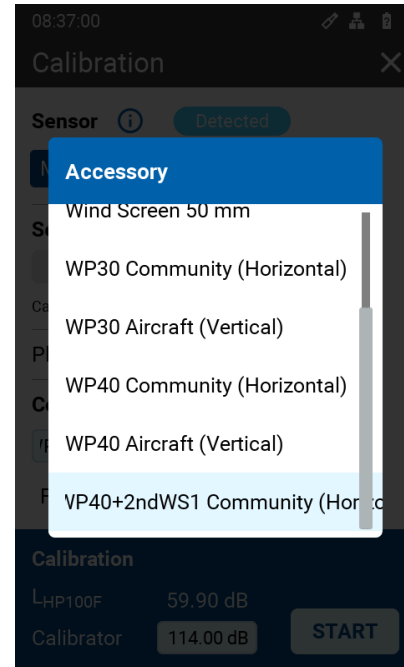
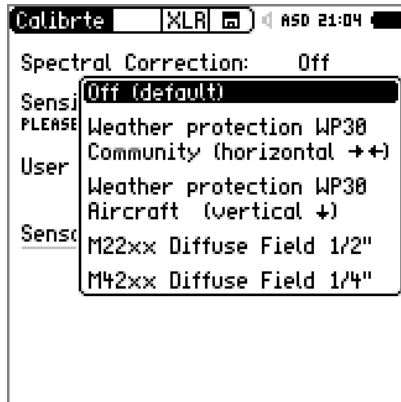

8 Technical Data Measurement Microphones

Nominal Frequency [Hz]	WP40 Weather Protection [dB] (Horizontal)		WP40 Weather Protection [dB] (Vertical)		WP40 WS1 Secondary Windshield [dB] (Horizontal)	
	1/3 rd Octave	1/1 Octave	1/3 rd Octave	1/1 Octave	1/3 rd Octave	1/1 Octave
< 800	0.00	0.00	0.00	0.00	0.15	0.15
800	0.06	0.15	-0.31	-0.35	0.37	0.56
1000	0.13		-0.37		0.56	
1250	0.25		-0.39		0.81	
1600	0.47	0.86	-0.28	0.04	1.20	1.65
2000	0.80		0.00		1.65	
2500	1.32		0.40		2.21	
3150	2.05	2.79	0.70	0.81	2.92	3.79
4000	2.88		0.82		3.79	
5000	3.44		0.92		4.45	
6300	3.70	3.69	0.81	0.62	4.68	5.03
8000	3.80		0.61		5.03	
10000	3.57		0.45		4.74	

Nominal Frequency [Hz]	WP40 Weather Protection [dB] (Horizontal)		WP40 Weather Protection [dB] (Vertical)		WP40 WS1 Secondary Windshield [dB] (Horizontal)	
	1/3 rd Octave	1/1 Octave	1/3 rd Octave	1/1 Octave	1/3 rd Octave	1/1 Octave
12500	4.94	6.18	1.85	3.98	5.31	5.59
16000	6.72		4.31		5.59	
20000	6.87		5.79		5.63	

Nominal Frequency [Hz]	WP30 Weather Protection [dB] (Legacy)		WP61 Weather Protection [dB] (Legacy)	
	1/3 rd Octave	1/1 Octave	1/3 rd Octave	1/1 Octave
< 800	0.0	0.0	0.0	0.0
800	0.0	0.0	0.0	0.0
1000	0.0		0.0	
1250	0.1		0.0	
1600	0.2	0.4	0.2	0.4
2000	0.3		0.3	
2500	0.7		0.8	

8 Technical Data Measurement Microphones

Nominal Frequency [Hz]	WP30 Weather Protection [dB] (Legacy)		WP61 Weather Protection [dB] (Legacy)	
	1/3 rd Octave	1/1 Octave	1/3 rd Octave	1/1 Octave
3150	1.3	2.0	1.4	2.0
4000	2.0		2.1	
5000	2.7		2.5	
6300	2.9	3.4	2.3	2.5
8000	3.3		2.4	
10000	3.9		2.8	
12500	4.6	5.9	3.0	3.0
16000	6.4		3.1	
20000	6.8		3.1	

9 Safety instructions

In the following, you will find important information on the safe operation of the device. Read and follow these safety notes and instructions. Keep the instructions for future reference. Ensure that it is available to all persons using the device.



DANGER! Threats for children

Make sure that plastic covers, packaging, etc. are disposed of properly and are not within the reach of babies and small children. Danger of suffocation! Ensure that children do not detach any small parts from the device (e.g. control knobs or similar). They could swallow the parts and choke on them! Do not allow children to use electrical equipment unsupervised.

NOTE! Operating conditions

Unless equipped with a Weather Protection kit, the device is designed for indoor use. To avoid damage, never expose the device to liquids or high humidity. Avoid prolonged direct sunlight, heavy dirt and strong vibrations.