



TURNING NOISE & VIBRATION
INTO INTELLIGENCE

 Made in Switzerland



Noise Locator NL1

Operating Manual

Version 2026-05-06

Table of Contents

1 Introduction	
2 Overview	
2.1 Composition of the Noise Locator NL1	<u>4</u>
2.2 Alignment to North	<u>4</u>
2.3 Package Contents	<u>4</u>
2.4 Spare parts	<u>5</u>
3 Measuring principle	
3.1 12 sound intensity probes	<u>6</u>
3.2 Quality indicator Delta P-I (dP-I)	<u>6</u>
3.3 Dynamic capability of Noise Locator NL1	<u>6</u>
3.4 Precautions for optimal measurement conditions	<u>7</u>
4 Assembling the Noise Locator NL1	
4.1 Mounting on the tripod	<u>8</u>
4.2 Mounting on the pole	<u>11</u>
4.3 Windshield replacement	<u>15</u>
5 More information	
5.1 My NTi Audio	<u>19</u>
5.2 Services and repairs	<u>19</u>
6 Warranty conditions	
6.1 International warranty	<u>20</u>
6.2 Warranty Limits	<u>20</u>
6.3 Statutory Rights	<u>20</u>
7 Disposal and recycling information	
7.1 Regulations for the EU and other European countries with corresponding laws	<u>21</u>
7.2 Other countries outside the EU	<u>21</u>
8 Tools supporting the Noise Locator NL1 Data	
8.1 XL3 (FW 1.54 or later)	<u>22</u>
8.2 MeasurEye	<u>23</u>
8.3 Data Explorer	<u>23</u>
8.4 NL1 Lab	<u>23</u>
9 Technical Specifications	
10 CE / FCC Declaration of Conformity	
11 Safety instructions	

1 Introduction

The Noise Locator NL1 is an all-weather sensor that identifies the direction of arrival of the predominant noise. It pairs with an outdoor microphone unit and compatible microphone (for example, WP40 + M2340) and connects via USB-A to the XL3 Acoustic Analyzer for power and real-time data logging.

The device performs octave analysis from 63 Hz to 4 kHz and reports overall A-weighted sound levels with selectable time resolution of 100 msec or 1 s. A built-in quality indicator quantifies the validity of each measurement.

Key features:

- Identification of the predominant noise;
- All-weather outdoor design;
- USB-A interface for real-time communication with XL3 Acoustic Analyzer and power;
- Octave analysis: 63 Hz–4 kHz and A-weighting;
- Time resolution: 100 msec or 1 s;
- Results expressed as Azimuth and Elevation;
- Measurement validity: Quality Indicator.

2 Overview

2.1 Composition of the Noise Locator NL1

The Noise Locator NL1 is composed of the following components:

- Fixed 5 m WP ASD cable routed through the housing;
- Top section with mounting provisions to secure a WPxx outdoor microphone unit by screw;
- Acoustically transparent metal grid that permits water drainage while maintaining acoustic performance;
- Windproof foam ball to reduce wind noise;
- Lower section housing the microphones and electronics, providing attachment for the top section and a threaded interface for the Lower Body Tube supplied with the WPxx;
- 5m cable terminating in a USB-A connector for power/data connection to the XL3 Acoustic Analyzer.

2.2 Alignment to North

The Noise Locator NL1 is designed for straightforward orientation and easy field installation.

Using the integrated North sight, the sensor can be aligned quickly to geographic north. Fine adjustment is achieved with the alignment hole, allowing precise orientation along the full axis from south to north: position the alignment hole on the right and point it toward north.

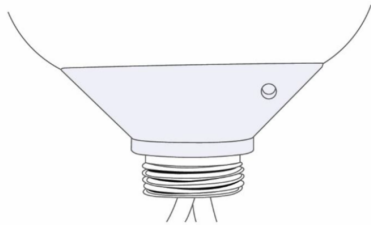

2.3 Package Contents

- The Noise Locator NL1 complete module — as described above;
- Allen wrench, 2.5 mm;
- WP tripod mounting plate with 2 cable outlets and three 20 mm nuts;
- Quick assembly guide;
- Individual calibration certificate.

2.4 Spare parts

- Noise Locator NL1 windscreen replacement — Item no. 600 041 001;
- Mounting plate for WP tripod — Item no. 600 040 072

3 Measuring principle

3.1 12 sound intensity probes

The Noise Locator NL1 integrates eight microphones positioned at the corners of an imaginary cube with 2 cm edges. Each microphone pair along a cube edge forms a sound intensity probe, yielding 12 intensity probes in total: four probes aligned with each of the X, Y and Z axes.

The direction of the intensity vector is computed by projecting the vector onto the XY plane to obtain the azimuth, and onto the Z axis to obtain the elevation.

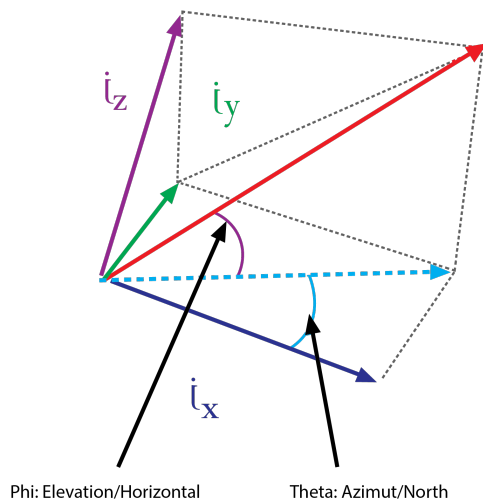

Angle convention:

- **Phi** — elevation (horizontal reference);
- **Theta** — azimuth (reference to north).

3.2 Quality indicator Delta P-I (dP-I)

The **dP-I** quality indicator is calculated per frequency band as the difference between the average pressure level across the eight microphones and the sound intensity level (the magnitude of the intensity vector).

- **dP-I \approx 0**: pressure and intensity levels are similar, indicating favorable measurement conditions (a single dominant source and minimal reflections);
- **dP-I**: intensity level is substantially lower than pressure level, indicating poor measurement conditions such as multiple simultaneous sources from different directions and/or a highly reactive field affected by reflections.

3.3 Dynamic capability of Noise Locator NL1

An intensity probe's dynamic capability is defined as the difference **dP-I₀** between the residual intensity level and the pressure level measured in a reverberant field (a field where energy arrives from all directions, producing near-zero net intensity). The Noise Locator NL1's dynamic capability was characterised in a reverberant room; the results are presented graphically in the measurement graph.

Quality indicator **dP-I** is defined as the opposite of the dynamic capability.

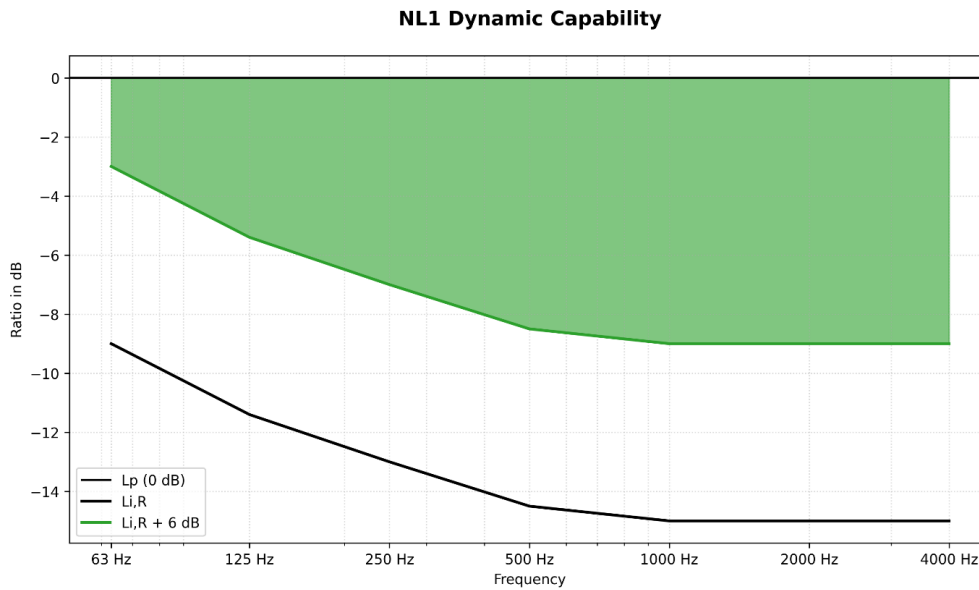

The NL1's directivity measurement is considered valid when $dP-I > dP-I_0 + 6 \text{ dB}$

3.4 Precautions for optimal measurement conditions

Sensor placement strongly affects Noise Locator NL1 performance. Observe the following guidelines where possible:

- **Avoid nearby reflective surfaces.** Do not install the Noise Locator NL1 close to façades or other vertical reflectors; any vertical reflective surface should be at least 5 m from the sensor to avoid disturbing azimuth measurements. In urban canyons or U-shaped streets with strong façade reflections, results may be unreliable;
- **Minimize ground reflections for elevation accuracy.** Mount the Noise Locator NL1 at a height of at least 3 m to reduce ground reflection effects on elevation measurements;
- **Position relative to sources.** Place the Noise Locator NL1 between the sources you wish to distinguish to optimise angular resolution. For example, to separate construction noise from traffic noise, position the sensor between the construction site and the traffic lane

4 Assembling the Noise Locator NL1

This section describes how to assemble the Noise Locator NL1 with the Weather Protection WPxx. Scan the codes below to view the complete assembly guide.

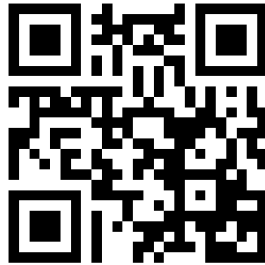

4.1 Mounting on the tripod

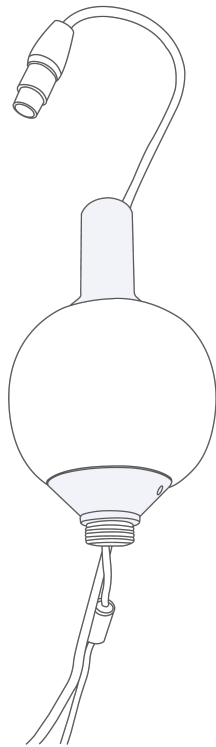

Step 1: Prepare the Components

Prepare the Noise Locator NL1 and WPxx with the microphone.

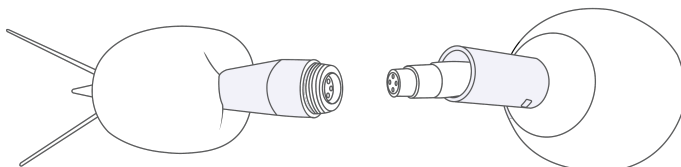

Step 2: Connect the Microphone

Connect the XLR cable on the top of Noise Locator NL1 to the microphone placed in WPxx.

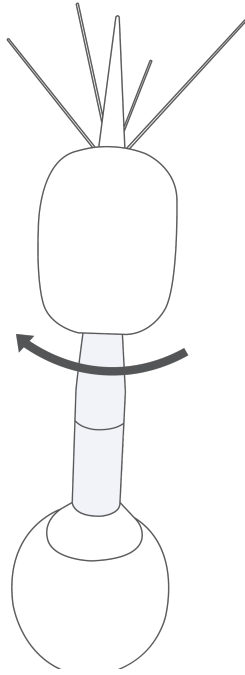

Step 3: Attach the WPxx

Screw the WPxx on the top of Noise Locator NL1.

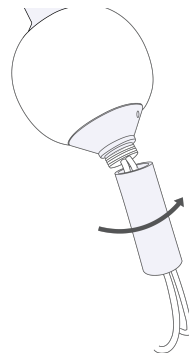

Step 4: Route the XLR Cable

Route the XLR cable through the tube first and then route the USB-A cable. You can find the tube in your WPxx set. Rotate the tube to screw that on the bottom of the Noise Locator NL1.

Step 5: Attach the Tripod Mounting Adapter

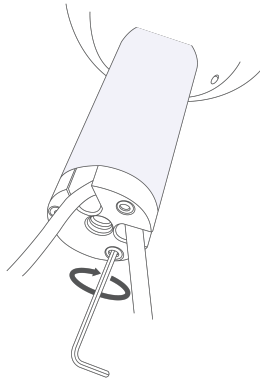

- **Torque:** Tighten the three M3×20 mm screws to a torque of 0.9–1.1 Nm.
- **Careful Installation:** These screws are threaded into plastic and must be tightened carefully. Do not over-tighten. Ensure the two parts are pulled flush against each other and that each screw is fully inserted.
- **Thread-Locking:** The screws are equipped with a blue Tuflok® thread-locking patch, which increases resistance during installation to prevent loosening. This resistance is normal.

Step 6: Final Connection and Mounting

You can now connect the XLR and USB-A cables from bottom of the Noise Locator NL1 to your XL3 Acoustic Analyzer and mount Noise Locator NL1 on the tripod.

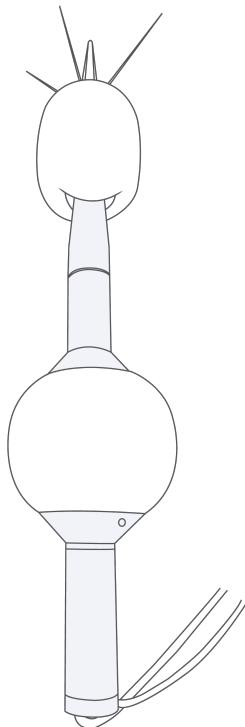

4.2 Mounting on the pole

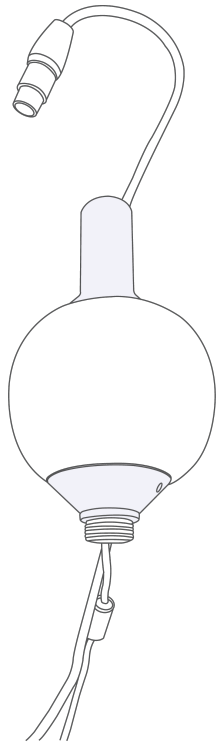

Step 1: Prepare the Components

Prepare the Noise Locator NL1 and WP40 with the microphone. See WPxx guide to prepare the WPxx and microphone.

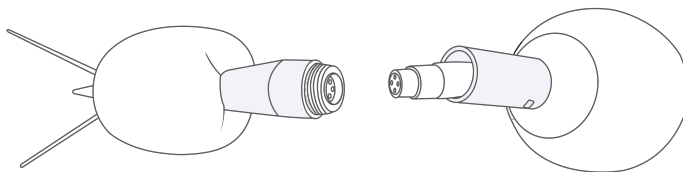
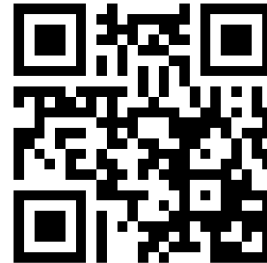

Step 2: Connect the Microphone

Connect the XLR cable on the top of Noise Locator NL1 to the microphone placed in WPxx.

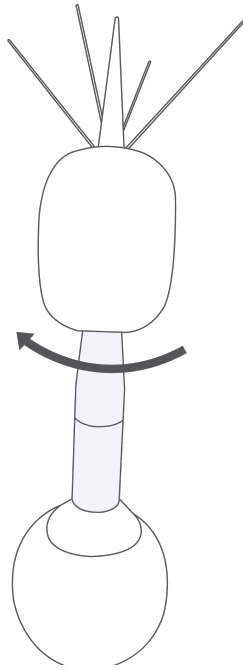

Step 3: Attach the WPxx

Screw the WPxx on the top of Noise Locator NL1.

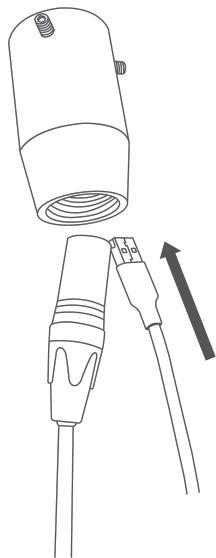

Step 4: Route Cable Through Pole Mount Adapter

Route the XLR cable through the pole mount adapter first and then route the USB-A cable.

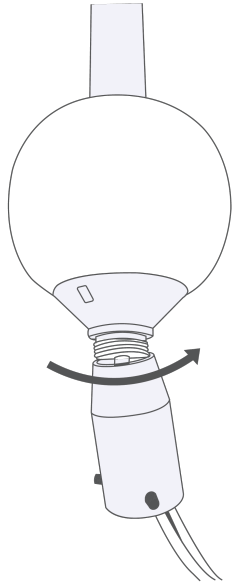

Step 5: Attach the Pole Mount Adapter

Rotate the pole mount adapter to screw that on the bottom of the Noise Locator NL1.

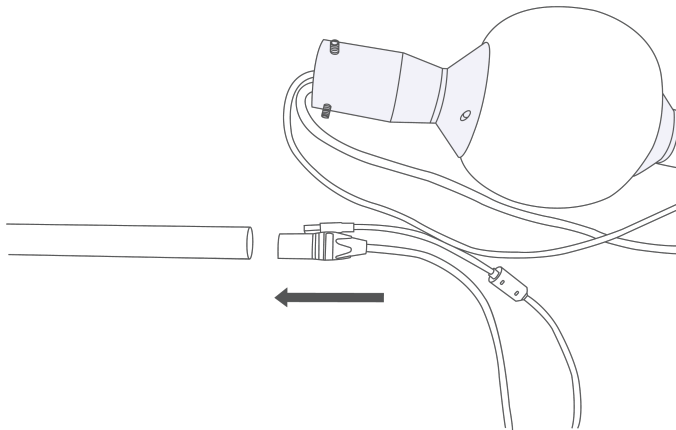

Step 6: Route Cable Through Pole

Route the XLR cable through the pole first and then route the USB-A cable.

Step 7: Ensure Complete Cable Routing

Ensure the cables are routed through the entire pole.

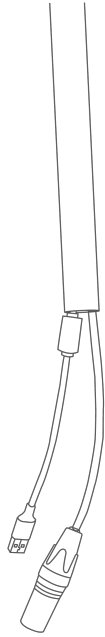

Step 8: Final Assembly and Connection

Attach the pole to the pole mount adapter and tighten the screw using an Allen key. Connect the XLR and USB-A cables to the XL3 Acoustic Analyzer.

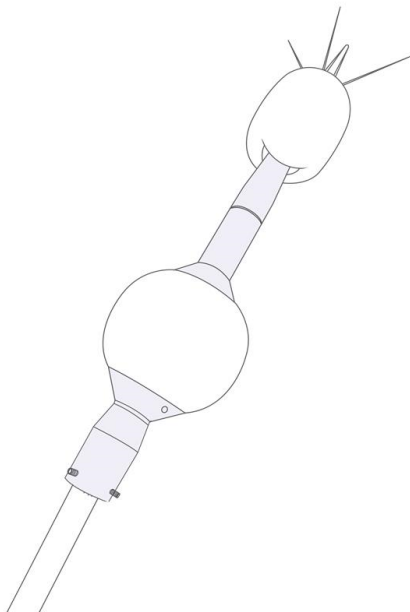

4.3 Windshield replacement

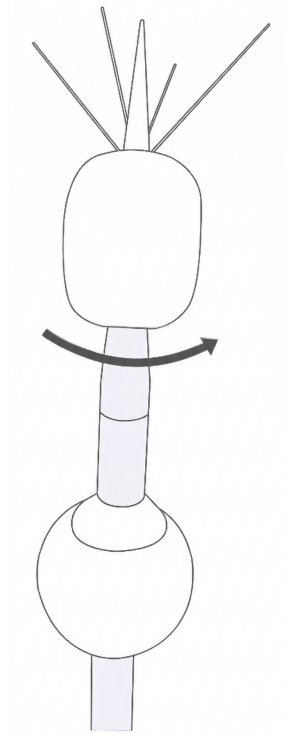

Step 1: Remove the WPxx

Unscrew the WPxx from Noise Locator NL1.

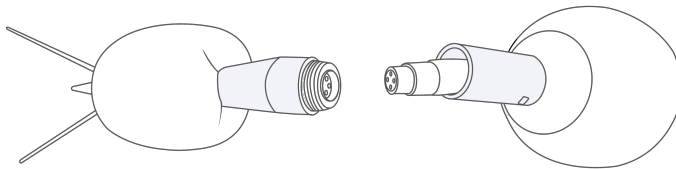

Step 2: Disconnect the XLR Cable

Disconnect the XLR cable placed between WPxx and upper part of Noise Locator NL1.

Step 3: Unscrew the Upper Part

Unscrew the upper part of the Noise Locator NL1.

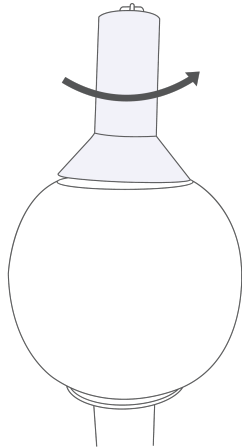

Step 4: Detach the Upper Part

Carefully slide the upper part to detach it from the base of Noise Locator NL1. The water repellent grid must remain attached to the upper part.

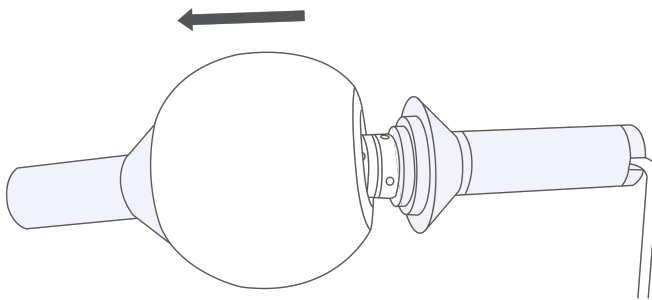

Step 5: Replace the Windshield

Replace the windshield on the upper part.

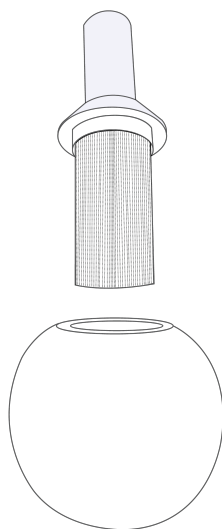

The metal mesh should not be touched with fingers, as grease or contamination can reduce its water-repellent properties.

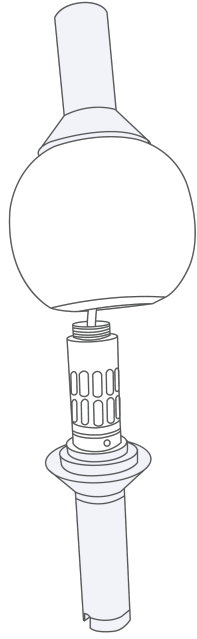

Step 6: Reattach the Upper Part

Attach the upper part with the new windshield back on the base of the Noise Locator NL1.



Step 7: Secure the Upper Part

Screw the upper part back in.

Step 8: Reconnect and Reassemble

Connect the XLR cable from the upper part of Noise Locator NL1 to the microphone in WPxx and screw the WPxx back on the top of the Noise Locator NL1.

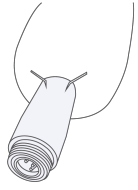

5 More information

5.1 My NTi Audio

Register your instruments on My NTi Audio and benefit from the following possibilities:

- Free updates for your instruments;
- Activation of optional product functions;
- Premium access to downloads;
- Receive application and product news;
- Faster worldwide support;
- Tracing support in case of loss or theft;
- Calibration support.

How to register:

- Open the web page my.ntiaudio.com;
- You are prompted to login or create your My NTi Audio account;
- The web page "My NTi Audio Products" opens;
- Select the product type and enter the serial number;
- Confirm with "Register";
- Now your product is listed in the table "My Products".

5.2 Services and repairs

If your product is not working properly or is damaged, please contact your local NTi Audio partner for assistance. If the product needs to be returned for repair, please follow the service instructions at <https://www.nti-audio.com/en/support/calibration-service>.

6 Warranty conditions

6.1 International warranty

NTi Audio warrants the operation of its products and their individual components up to three years from the date of sale. During this period, defective products will either be repaired free of charge or replaced.

6.2 Warranty Limits

These warranty provisions do not cover damage caused by accidents, transportation, misuse, neglect, non-original accessories, loss of parts, use with unspecified input voltages, adapter types, or improperly inserted batteries. NTi Audio accepts no liability for subsequent damages of any kind. The warranty will be void if repairs or services are performed by third parties who are not part of an authorized NTi Audio service center.

6.3 Statutory Rights

Consumers may have legal (statutory) rights under national laws applicable to the sale of consumer products. This warranty does not affect your statutory rights. You may assert your legal rights in your sole discretion.

7 Disposal and recycling information

Dispose of the instrument in accordance with the country's environmental legal provisions.

7.1 Regulations for the EU and other European countries with corresponding laws

The instrument should not be disposed of in household waste. At the end of its service life, take the instrument to a collection point for electrical recycling, in accordance with local legal provisions.

7.2 Other countries outside the EU

Contact the relevant authorities to find out what environmental regulations are in place in your country.

8 Tools supporting the Noise Locator NL1 Data

8.1 XL3 (FW 1.54 or later)

The XL3 Acoustic Analyzer records Noise Locator NL1 data whenever the Noise Locator NL1 is connected, a measurement is running, and a logging interval (100 ms or 1 s) is selected. A log file with the suffix `_NoiseLoc_Log.txt` is then created.

Excerpt from a `NoiseLoc_log.txt` file:

```

XL3 Noise Locator Logging:
-----

# Hardware Configuration
Device Info:      XL3, SNo. A3A-00500-D1, FW1.54, My XL3
Noise Locator:   NL1, SNo. 138, FW1.1.1.10
Time Zone:       Europe/Paris (UTC +01:00)

# Measurement Setup
Configuration:    NL1-Eval_100ms
Timer mode:       Continuous
Timer set:        --:--:--
Log-Interval:     00:00:00.1

# Time
Start:            2026-03-17, 13:07:21

# Noise Locator Log Results

Date              Time              Timer              Band [Hz]          NL_Lp_dt           NL_dPI_dt           NL_Az_dt           NL_EL_dt           NL_Lp_dt
[YYYY-MM-DD]     [hh:mm:ss]       [hh:mm:ss]        [dB]               [dB]               [deg]              [deg]              [dB]
2026-03-17       13:07:21         00:00:00.1        ---                34.1                4.9                135                -14                20.6
2026-03-17       13:07:21         00:00:00.2        ---                34.0                5.2                137                -20                20.2
2026-03-17       13:07:21         00:00:00.3        ---                32.9                5.8                129                -6                 20.8
2026-03-17       13:07:21         00:00:00.4        ---                32.0                5.8                118                3                 20.4
2026-03-17       13:07:21         00:00:00.5        ---                31.2                5.8                113                1                 20.4
2026-03-17       13:07:21         00:00:00.6        ---                30.8                5.6                97                 16                19.9
2026-03-17       13:07:21         00:00:00.9        ---                31.8                5.9                117                -3                19.9
2026-03-17       13:07:21         00:00:00.8        ---                31.8                5.9                117                -3                19.9
2026-03-17       13:07:21         00:00:01.9        ---                31.4                6.7                113                -9                20.2
2026-03-17       13:07:22         00:00:01.0        ---                31.2                6.5                100                -16               20.4
2026-03-17       13:07:22         00:00:01.1        ---                31.0                6.4                100                4                 20.4
2026-03-17       13:07:22         00:00:01.2        ---                33.0                5.8                135                4                 20.4
2026-03-17       13:07:22         00:00:01.3        ---                33.3                5.8                135                -25               20.7
2026-03-17       13:07:22         00:00:01.4        ---                33.0                5.6                143                -23               20.4
2026-03-17       13:07:22         00:00:01.5        ---                33.3                5.5                134                -20               20.7
2026-03-17       13:07:22         00:00:01.6        ---                33.3                5.5                134                -20               20.7
2026-03-17       13:07:22         00:00:01.7        ---                38.0                3.7                149                -30               21.2
    
```

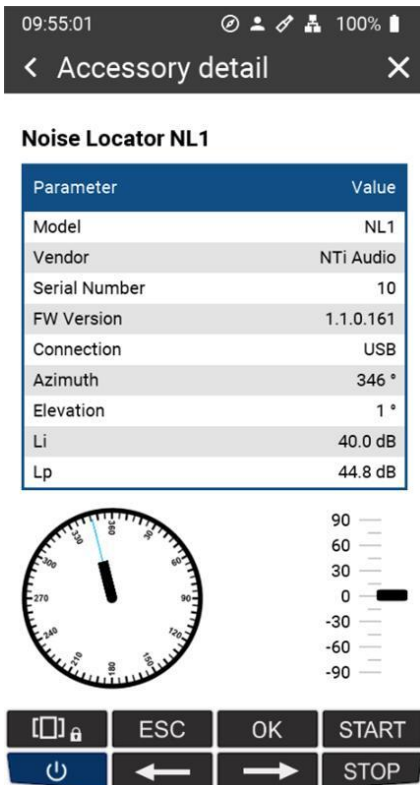

- The XL3 Acoustic Analyzer provides an overview of the Noise Locator NL1 parameters under System Settings -> Accessory List -> Noise Locator NL1;
- The Noise Locator NL1 parameters are available through the Streaming API interface and are synchronized with the SPL log data.

8.2 MeasurEye

- When the Noise Locator NL1 is connected to the XL3 Acoustic Analyzer, you can enable Noise Locator NL1 readings in the Monitor Info screen;
- Define a segment. Only noise coming from the segment is accumulated

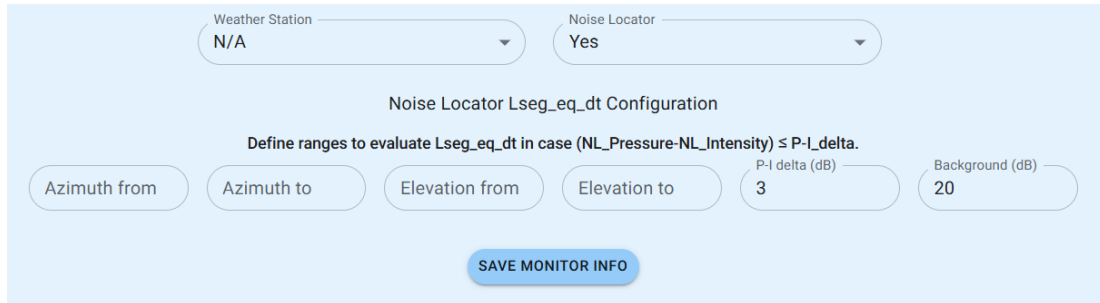

- The parameters provided by Noise Locator NL1 will be displayed in both the Real-Time Data view and the Historical Data view. These parameters can also be used in the Events view as an alarm triggers or contributing factors to the events.

8.3 Data Explorer

The Data Explorer generates markers based on segment definitions and visualizes Noise Locator NL1 data. Available during Q1/2026.

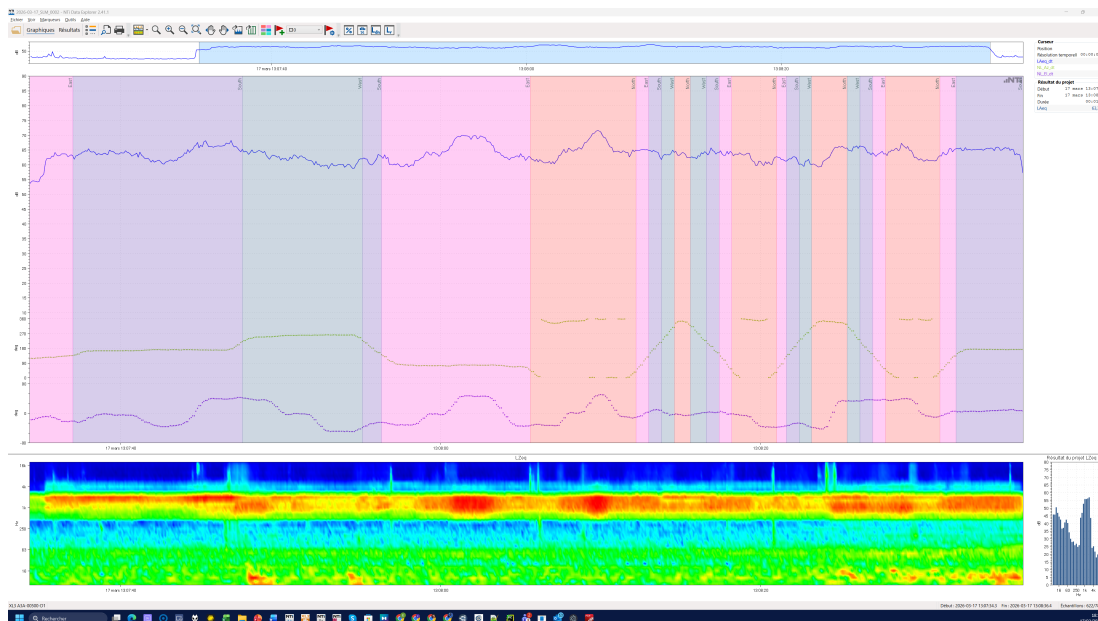

8.4 NL1 Lab

An experimental project to demonstrate the capabilities of the Noise Locator NL1 which is available at <https://my.nti-audio.com/nl1lab/>.

The screenshot displays the NTI Audio NL1 Lab software interface. At the top left is the NTI Audio logo. The main header includes 'NL1 Lab v1.0.1' and navigation tabs for 'Dashboard', 'Camera', 'Settings', and 'Debug'. A 'CONNECTED' status indicator is visible in the top right.

The interface is divided into several sections:

- Map View:** A map showing a residential area with a central noise locator icon. A circular sector is highlighted, and a 'Heatmap' button is present.
- Sectors Panel:** A grid of noise sector data cards. Each card displays:
 - Sector ID (e.g., Az0°/El-90°)
 - LAeq_g0.167 value (35.0 dB)
 - LAeq_in_g0.167, LAeq_bg, T_in, and T_total values.
- Lp History:** A graph showing noise level history over time. The y-axis ranges from -10 to 60, and the x-axis shows time in seconds (0s to 5s). The current status is 'No history yet...'. A 'Bands' selector is located above the graph.
- Direction Indicators:** A section at the bottom with the message 'No data available. Connect to NL1 stream first.'

9 Technical Specifications

The Noise Locator NL1 is an all-weather sensor that identifies the direction of arrival of the predominant noise. It pairs with an outdoor microphone unit and compatible microphone (for example, WP40 + M2340) and connects via USB-A to the XL3 Acoustic Analyzer for power and real-time data logging.

The device performs octave analysis from 63 Hz to 4 kHz and reports overall A-weighted sound levels with selectable time resolution of 100 msec or 1 s. A built-in quality indicator quantifies the validity of each measurement.

Key features

- Identification of the predominant noise
- All-weather outdoor design
- USB-A interface for real-time communication with XL3 and power
- Octave analysis: 63 Hz–4 kHz and A-weighting
- Time resolution: 100 msec or 1 s
- Results expressed as Azimuth and Elevation
- Measurement validity: Quality Indicator **dP-I**

Interface

- Single USB-cable for power and data
- Data transmitted via USB interface, including per-octave information
- Device powered directly via USB (< 1 W)

Technical Specifications

- Sound direction analysis
- Frequency response: octave bands from 63 Hz to 4 kHz
- Dynamic Range: 40 dBA to 125 dBA
- Absolute Level Accuracy: 94 dBSPL @ 1 kHz \pm 1.5 dB
- **Accuracy of directivity angles:**
 - In azimuth @ Elevation [-60° to + 60°], all tolerance values as [Maximum (Typical)]

Oct. [Hz]	63	125	250	500	1000	2000	4000	A weighted
Tolerance [°]	\pm 35 (\pm 15)	\pm 20 (\pm 15)	\pm 15 (\pm 10)	\pm 10	\pm 10	\pm 10	\pm 20	\pm 10

- **Maximum tolerance of Spherical Directivity Angles:**

- In azimuth (all specs +/-): Elevation [-60° to +60°]

Oct. [Hz]	63	125	250	500	1000	2000	4000	A weighted
Tolerance [°]	\pm 35	\pm 20	\pm 15	\pm 10	\pm 10	\pm 10	\pm 20	\pm 10

- In elevation (all specs +/-): Azimuth [-180° to +180°]

Oct. [Hz]	63	125	250	500	1000	2000	4000	A weighted
Tolerance [°]	\pm 35	\pm 20	\pm 15	\pm 15	\pm 10	\pm 15	\pm 25	\pm 10

- **Residual Noise:**

Oct. [Hz]	63	125	250	500	1000	2000	4000	A weighted
Upper Tolerance [dBSPL]	22	20	16	15	16	18	21	27

Environment

- Operating temperature: -10 °C to +50 °C
- Wind resistance: up to 120 km/h without damage
- Relative humidity: 25% to 90% (non-condensing)
- Rain protection: the shape, windscreen and metal grid provide excellent protection against rain, wind and dust

10 CE / FCC Declaration of Conformity

We, the manufacturers NTi Audio AG, Im alten Riet 102, 9494 Schaan, Liechtenstein, declare under our sole responsibility that the product Noise Locator NL1 in all its possible configurations and including any additional OEM accessories is in conformity with the following relevant Union harmonization legislation:

Directive:

- Directive 2014/30/EU of the European Parliament and of the Council of 26 February 2014 on the harmonisation of the laws of the Member States relating to electromagnetic compatibility (EMC Directive)
- Directive 2014/35/EU of the European Parliament and of the Council of 26 February 2014 on the harmonisation of the laws of the Member States relating to electrical equipment designed for use within certain voltage limits (Low Voltage Directive);
- Directive 2011/65/EU of the European Parliament and of the Council on the restriction of the use of certain hazardous substances in electrical and electronic equipment (RoHS).

Standards Safety:

- EN 62368-1:2014/A11:2017. Audio/video, information and communication technology equipment – Safety requirements.

Electromagnetic Compatibility EMC:

- EN IEC 61326-1:2021. Electrical equipment for measurement, control and laboratory use – EMC requirements – General requirements.
- EN 55011:2016 + A1:2017 + A11:2020 + A2:2021. Industrial, scientific and medical equipment – Radio-frequency disturbance characteristics – Limits and methods of measurement (Group 1, Class B).

RoHS:

- EN 63000:2018. Technical documentation for the assessment of electrical and electronic products with respect to the restriction of hazardous substances.

The conformity assessment procedure has been carried out under the sole responsibility of the manufacturer. The product has been tested according to the applicable standards and complies with the essential requirements of the listed directives. This declaration is valid as long as no modifications are made to the product without written authorization from NTi Audio AG.

Place and date of issue: Schaan,
26.02.2026

Name and function: CEO, Hansjörg
Prettner

Signature:



11 Safety instructions



NOTE! Operating conditions

Ensure that the device is operated within the specified temperature range of -10°C to +50°C (14°F to 122°F).



DANGER! Electrical Safety

Regularly inspect all cables and connections for signs of wear or damage. Do not use damaged equipment.



DANGER! Threats for children

Do not allow children to use electrical equipment unsupervised.